

DIRECTIE M
Afdeling 22-2
Sectie 2

222.50

Vorbereidingscursus
tot de
beroepsvorming
van de
leerling - bestuurders.

Rekenkunde - Mechanika - Electriciteit.

Tekeningen



Boek I
Lessen 1 tot 48.

1979

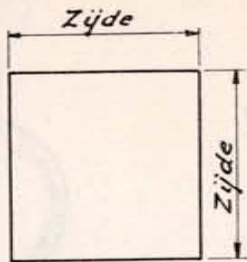

Fig. 9-1.

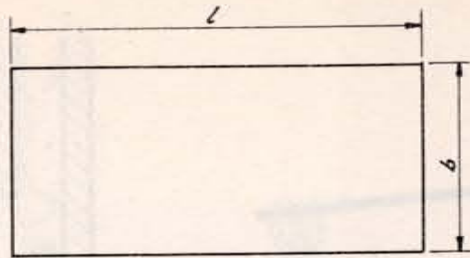

Fig. 9-2

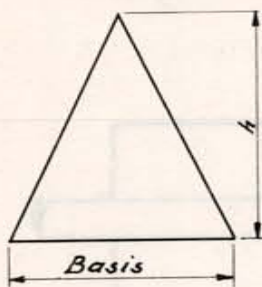

Fig. 9-3.

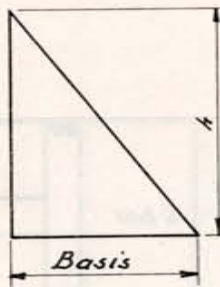

Fig. 9-4.

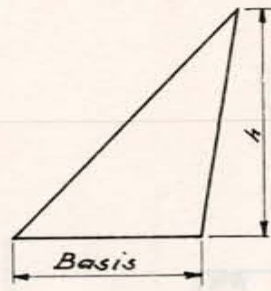

Fig. 9-5.

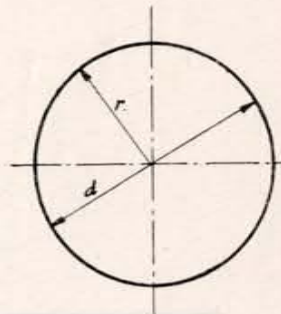

Fig. 9-6.

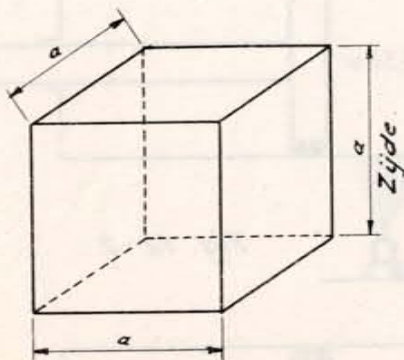

Fig. 10-1.

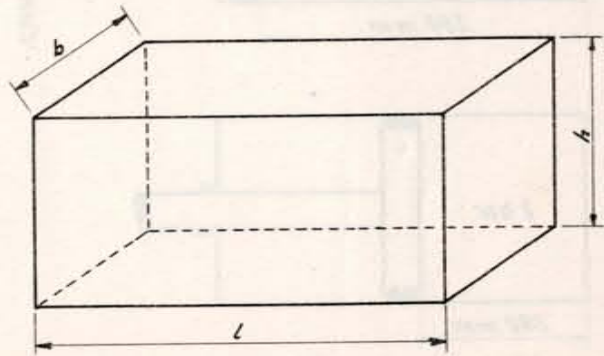

Fig. 10-2.

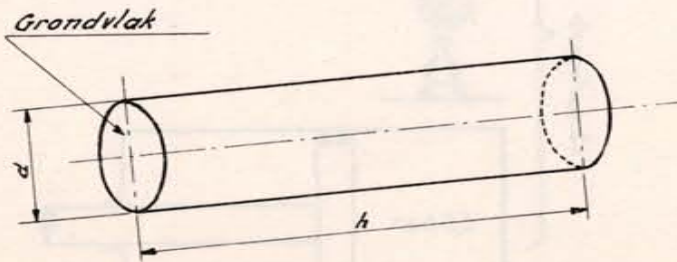

Fig. 10-3.

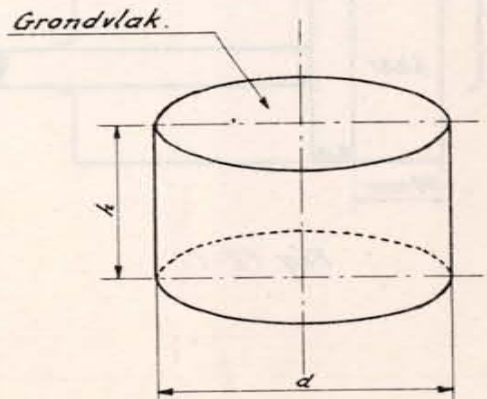

Fig. 10-4.

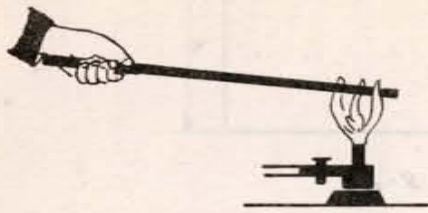

Fig. 11-1.

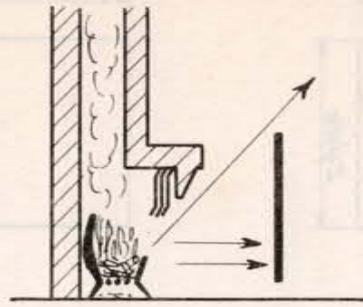

Fig. 11-2.

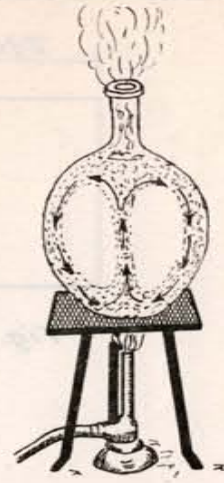

Fig. 11-3.

Constante temperatuur.

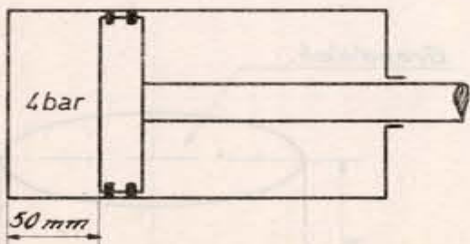
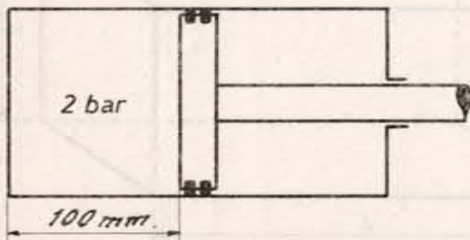
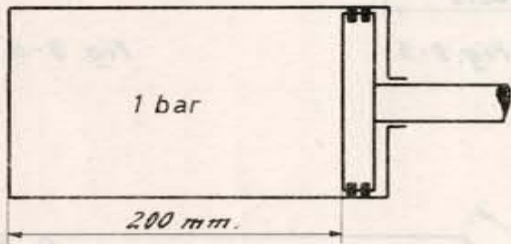

Fig. 12-1.

Constant volume.

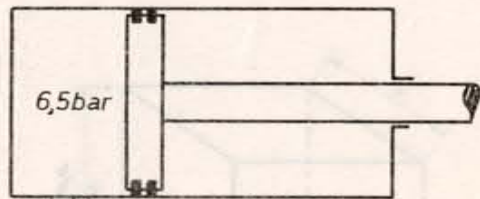
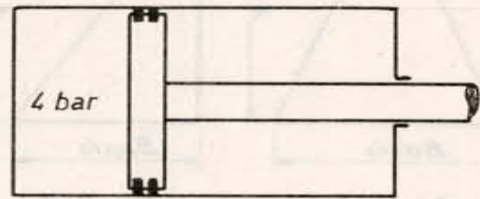

Fig. 12-2.

Constante druk.

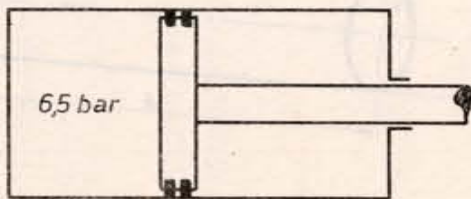
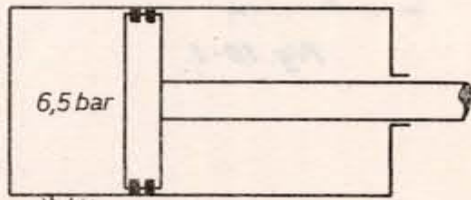

Fig. 12-3



Fig. 13-1.

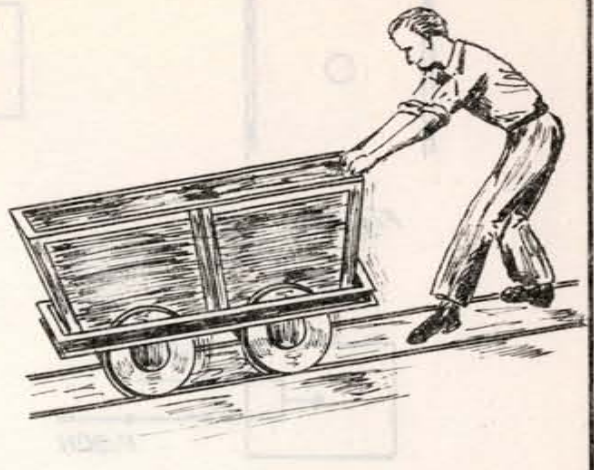

Fig. 13-2.

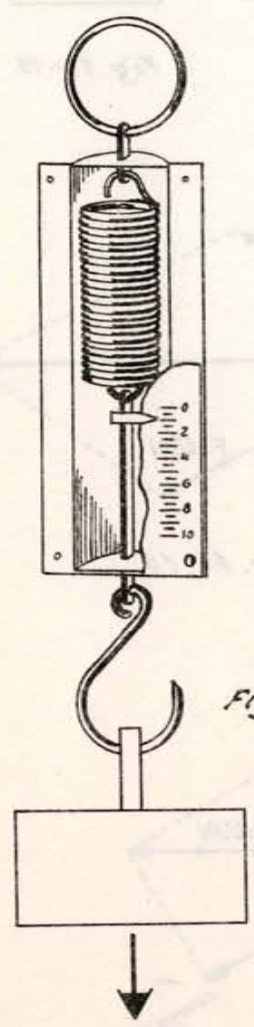

Fig. 13-3.

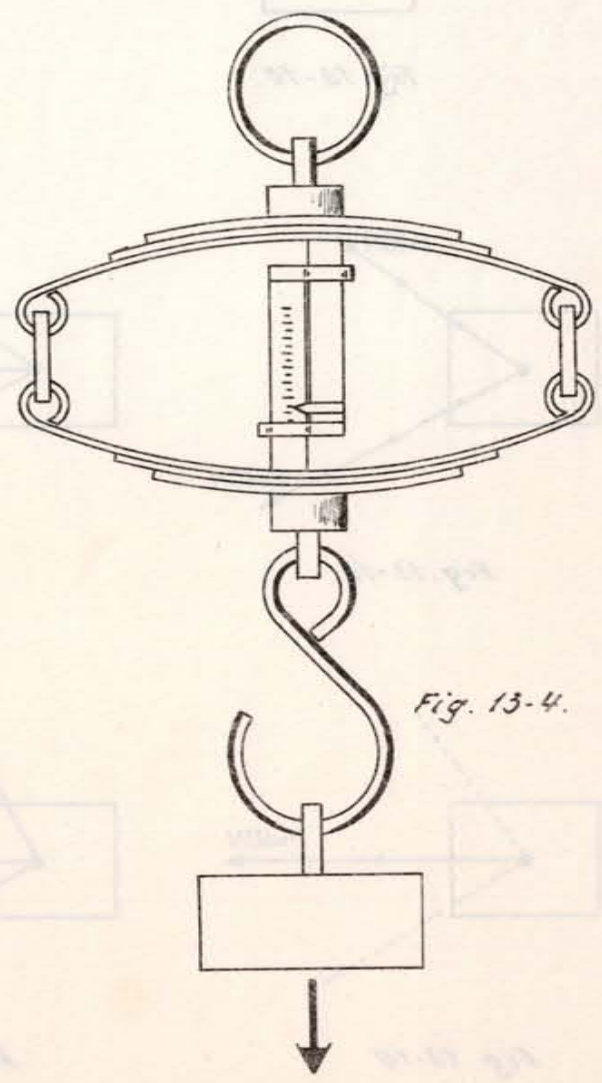

Fig. 13-4.

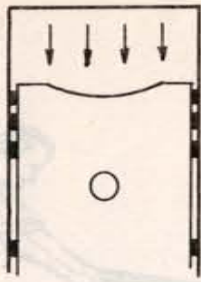

Fig. 13-5.

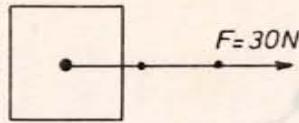

Fig. 13-6

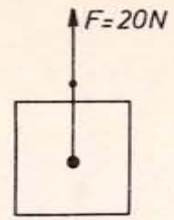

Fig. 13-7

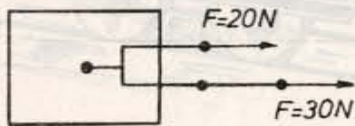

Fig. 13-8.

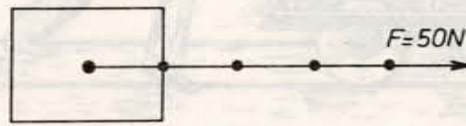

Fig. 13-9.

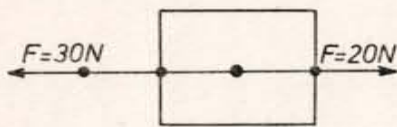

Fig. 13-10.



Fig. 13-11.

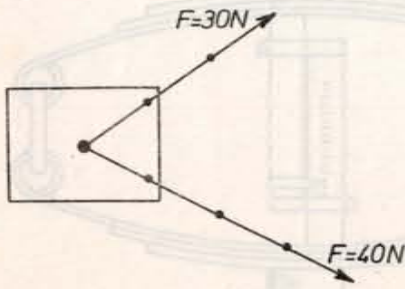

Fig. 13-12.

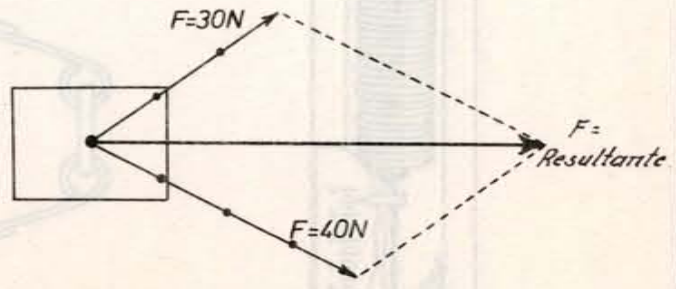

Fig. 13-13.

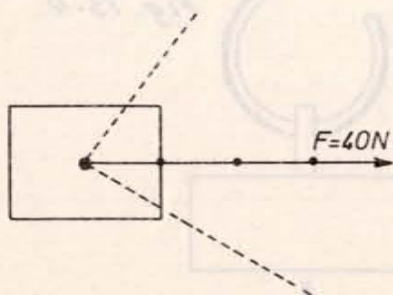

Fig. 13-14

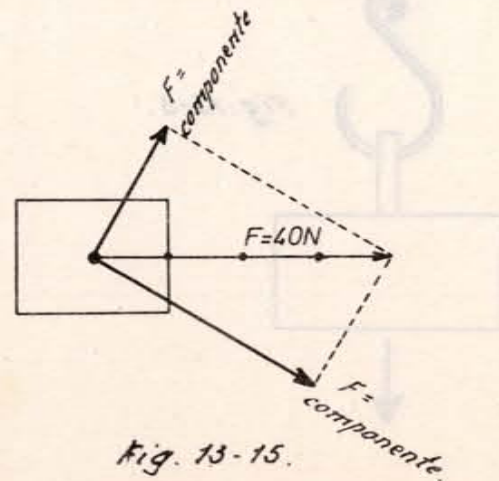

Fig. 13-15.

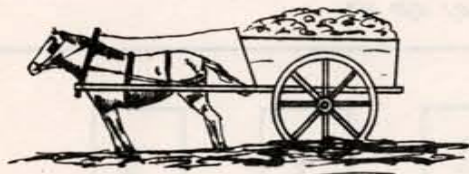

Fig. 14.1.



Fig. 14.2.

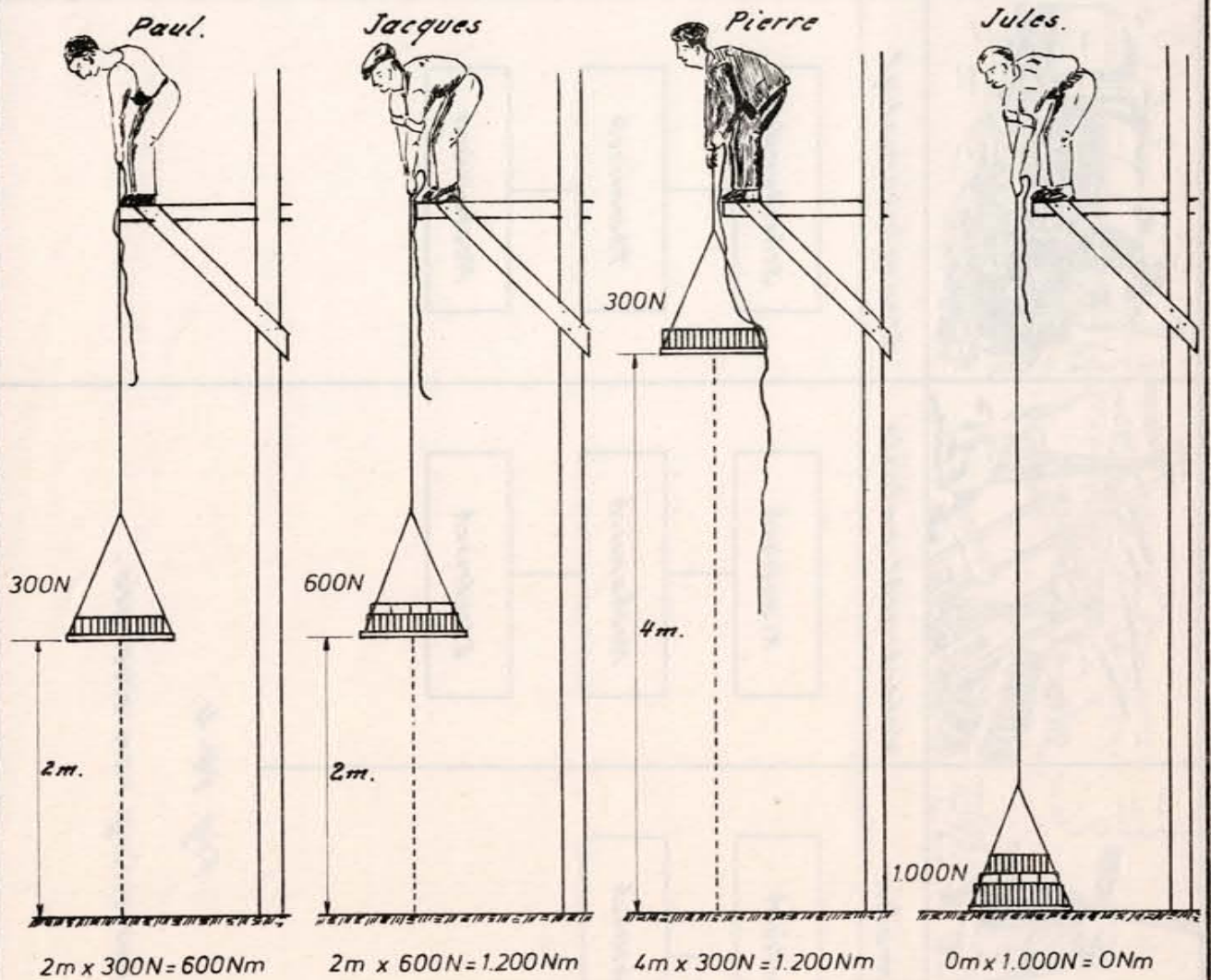

Fig. 14.3.

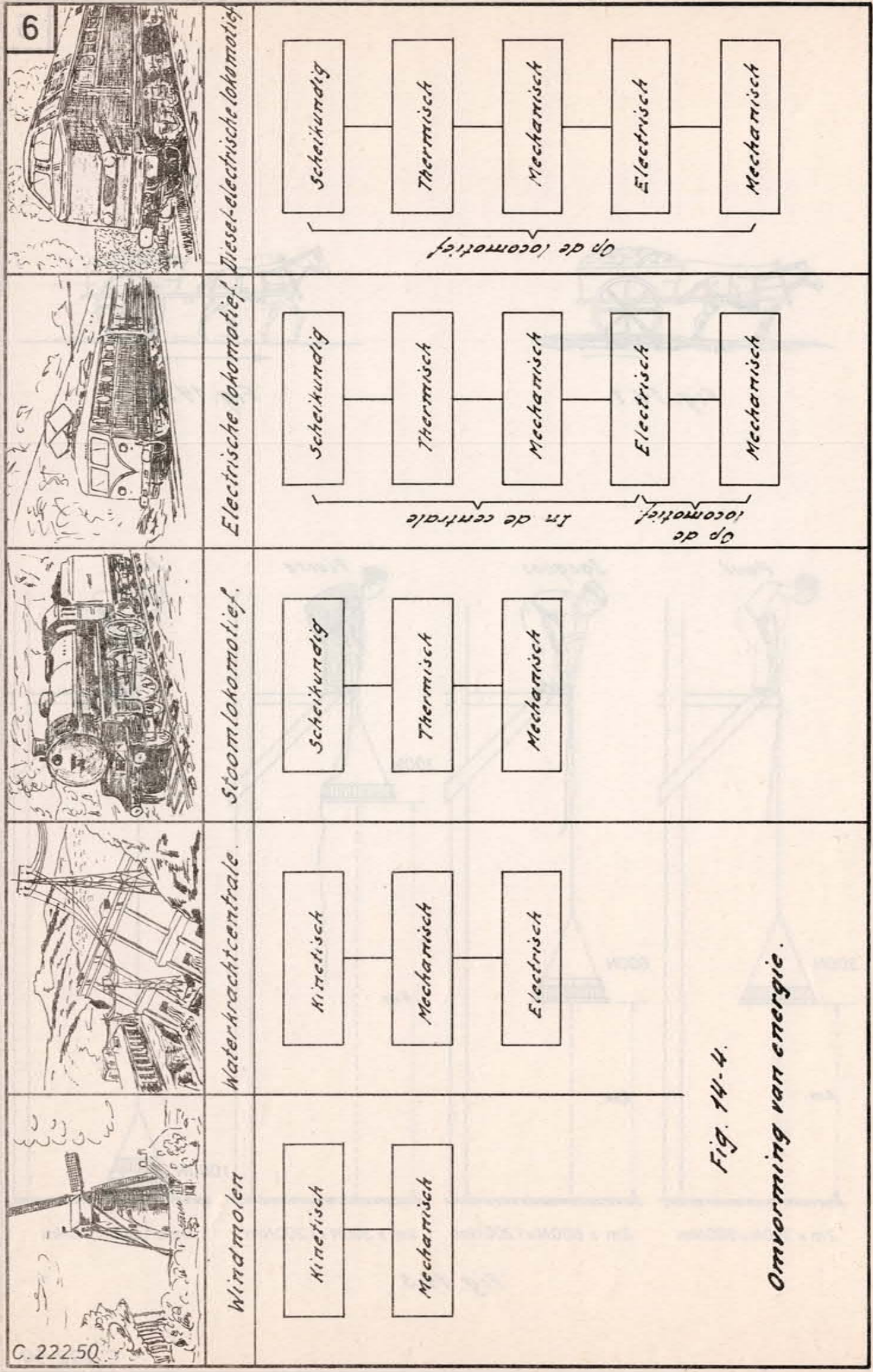

Fig. 14-4.
Omvorming van energie.

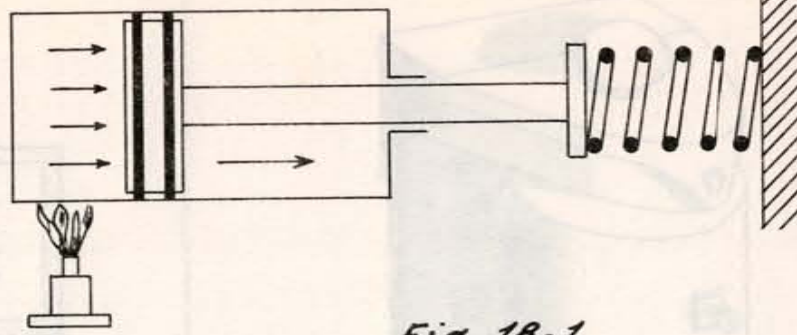

Fig. 18-1.

Stoommachine als voorbeeld van de thermische motor met uitwendige verbranding.

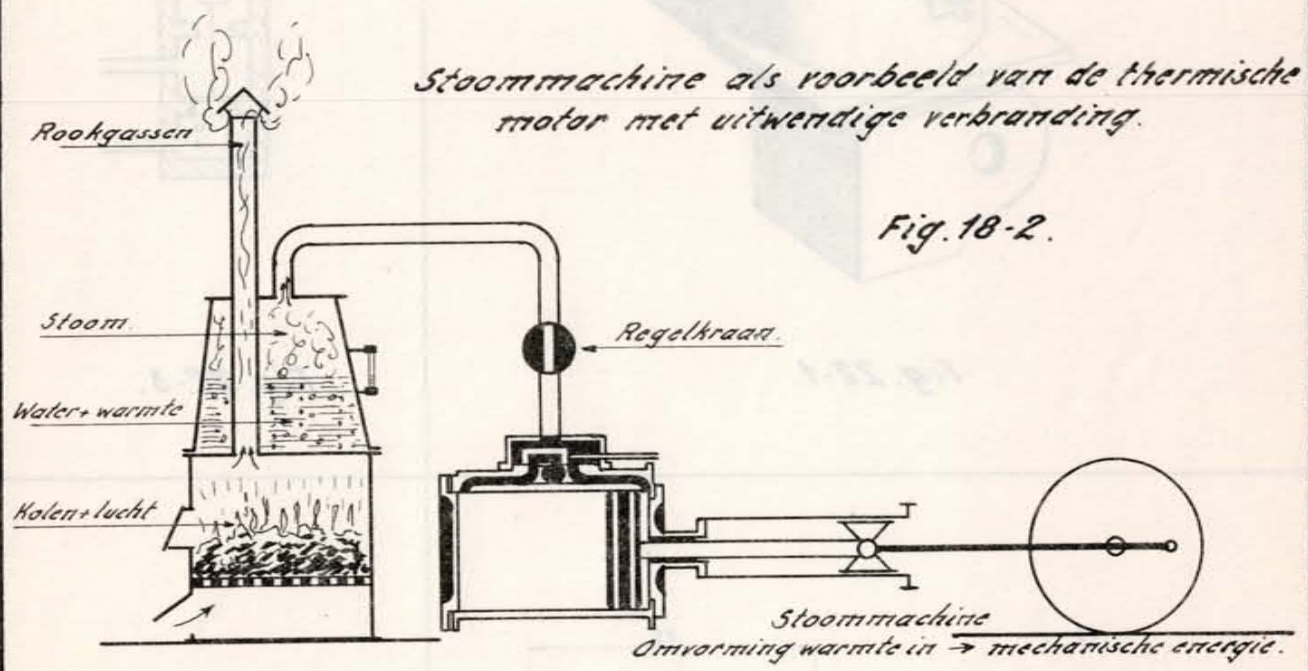

Fig. 18-2.

Principe van de thermische motor met uitwendige verbranding.

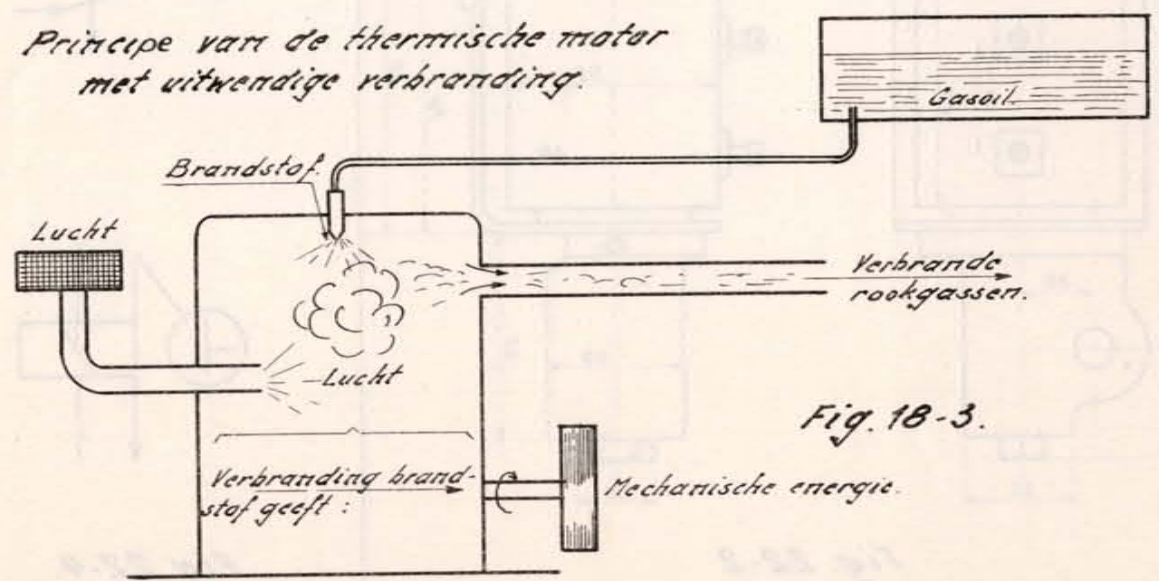

Fig. 18-3.

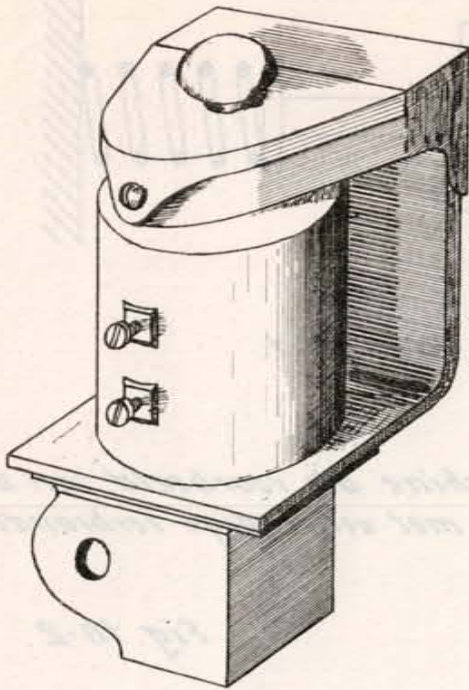

Fig. 22-1.

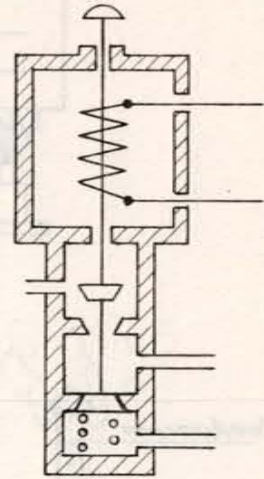

Fig. 22-3.

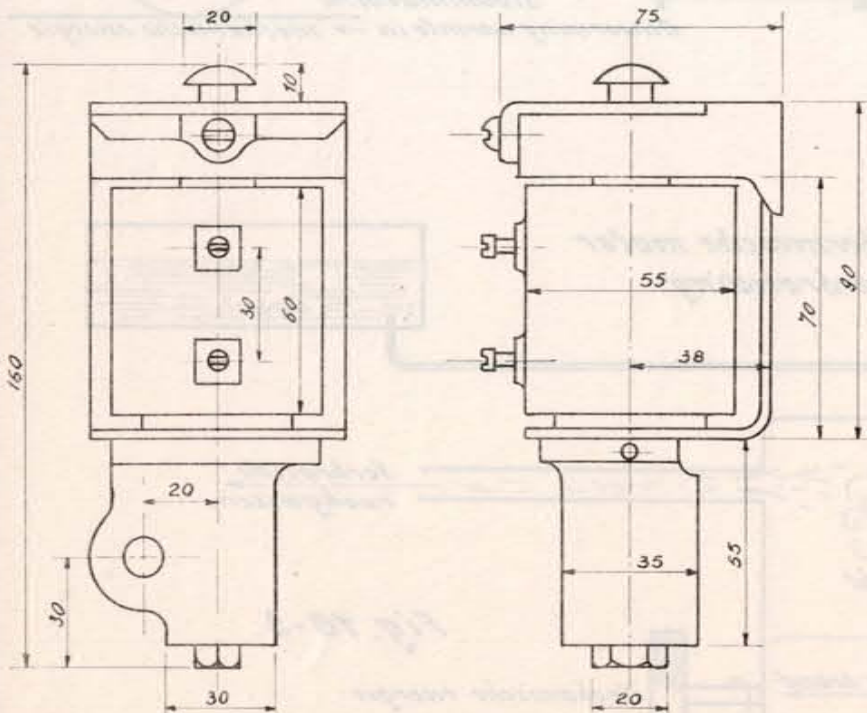

Fig. 22-2

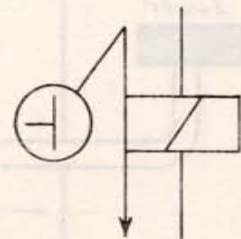
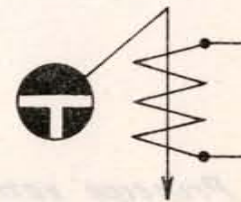

Fig. 22-4.

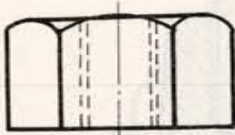

Fig. 23.1.



Fig. 23.2.

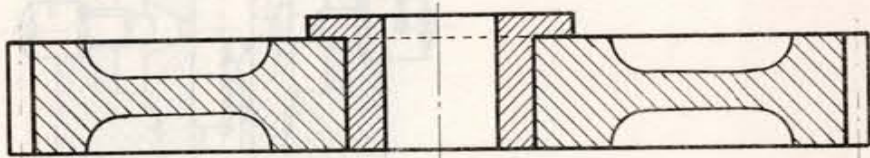

Fig. 23.3.

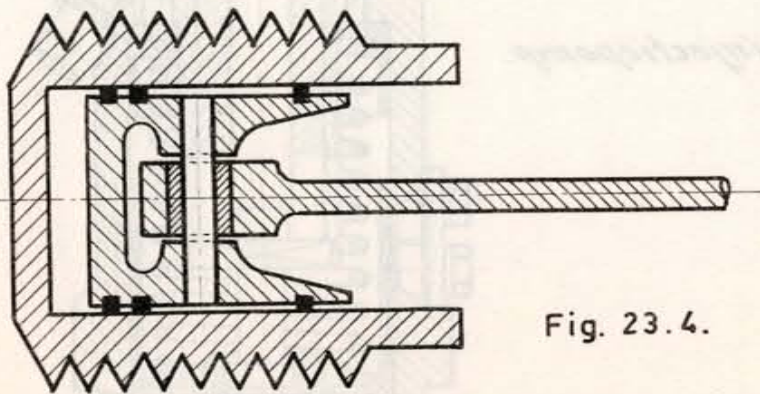
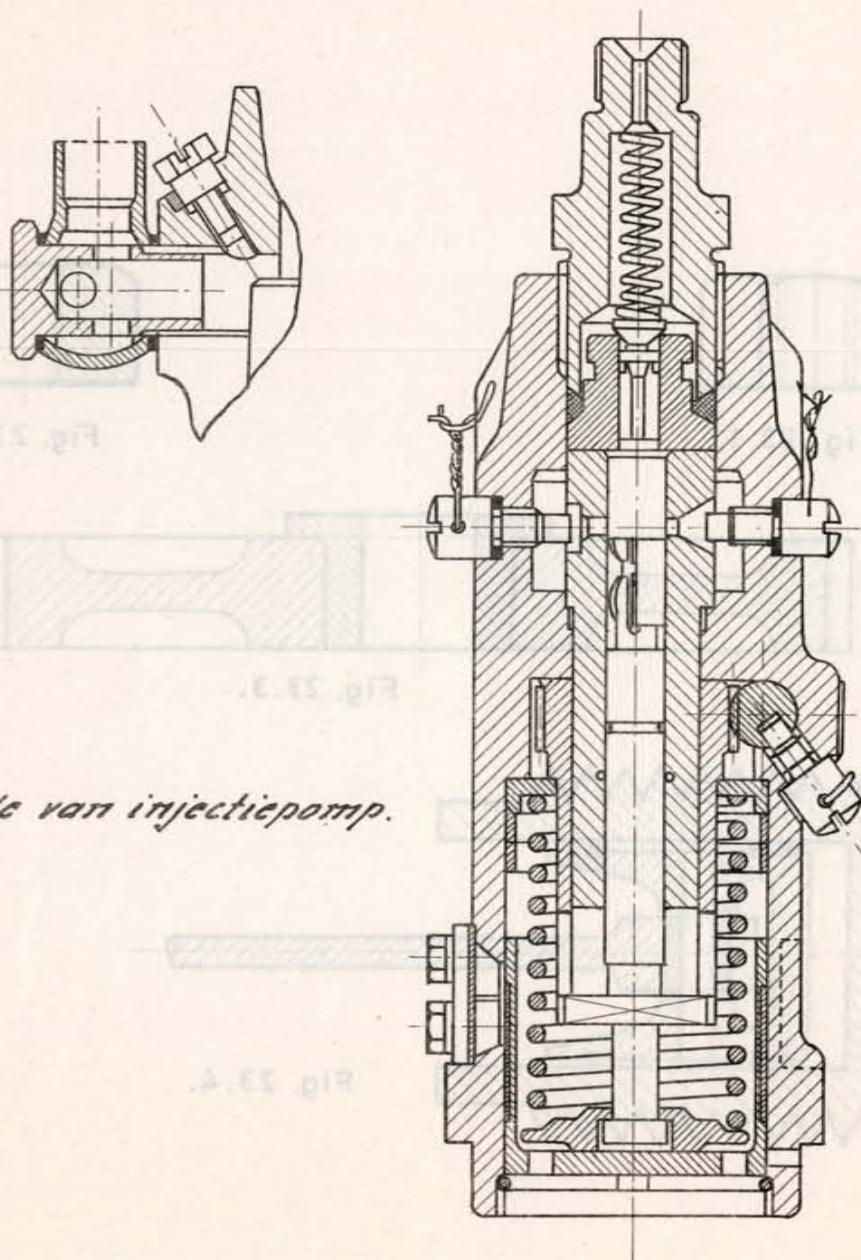
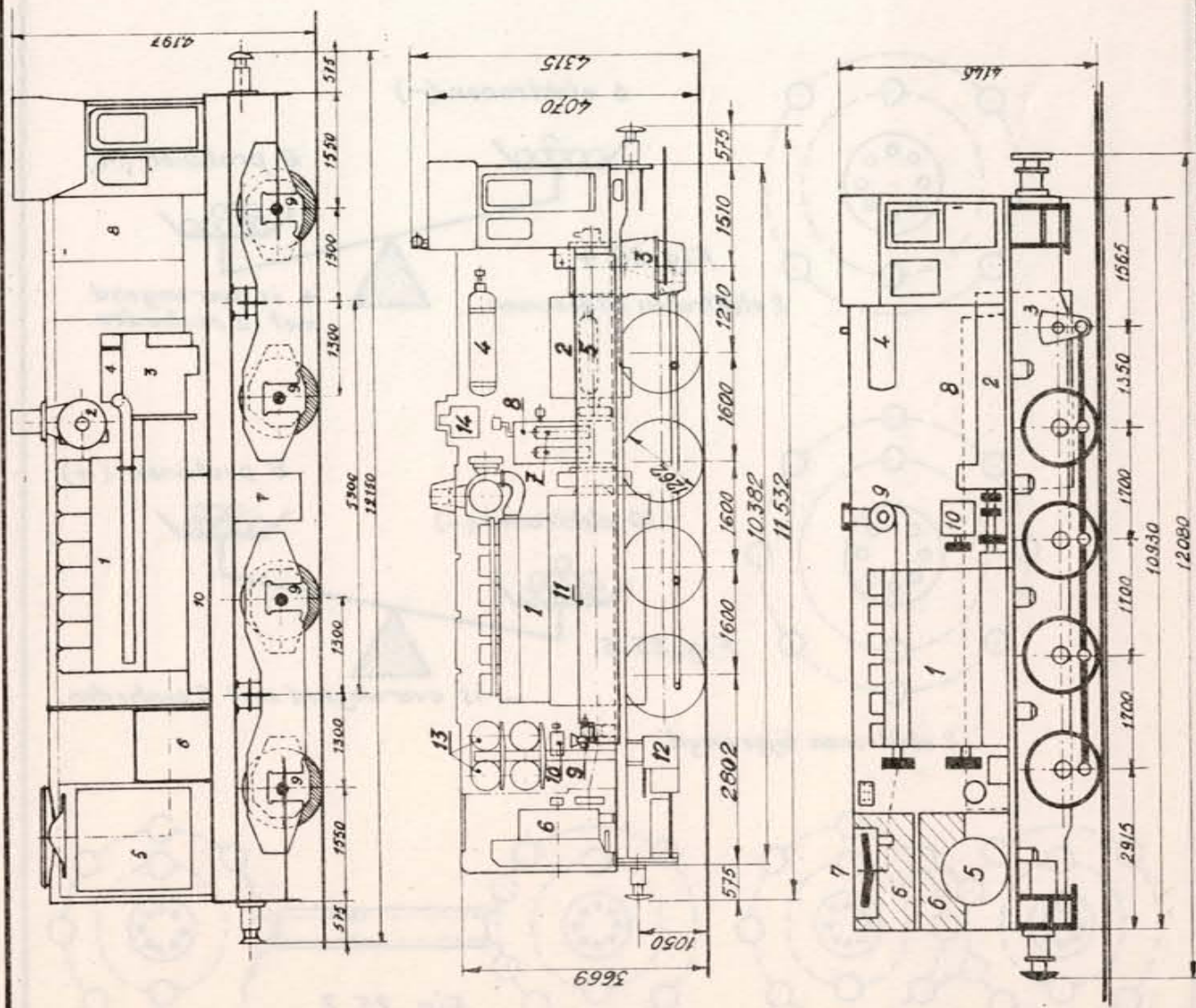

Fig. 23.4.



Doorsnede van injectiepomp.

Fig. 24-3.



- Dieselmotor.*
 1. *Vuldrukturbo*
 2. *Hoofdgenerator.*
 3. *Hulpgroep.*
 4. *Radiatoren.* — *Lokomotief R.70*
 5. *Motorolie-reservoir*
 6. *Gasoliereservoir*
 7. *Toestellenkast*
 8. *Trekliemotoren.*
 9. *accumulatorenkast.*

- 1 *Motor SEM 6B35*
 2 *Turbo- overbrenging Voith.*
 3 *Omkeer- reductor "Mylius.*
 4 *Startflessen*
 5 *Warmte wisselaar*
 6 *Afkoelgroep "Voith. (radiator en ventilator)*
 7 *Oliefilter*
 8 *Compressor* — *Lokomotief R.71*
 9 *Waterpomp*
 10 *Dynamo*
 11 *Gasolie vergaarbakken*
 12 *Baflerijen*
 13 *Hooftereservoirs*
 14 *Expansievat*

- 1 *Dieselmotor.*
 2. *Hydraulische overbrenging type Voith L 37Z.*
 3. *kruk met vaise as.*
 4. *Luchtdrukflessen voor aanzetten.*
 5. *Hoofdvergaarbak.*
 6. *Radiatoren.*
 7. *Ventilatoren.* — *Lokomotief R.72*
 8. *Gasolievergaarbak.*
 9. *Turbo- blazer.*
 10. *Compressor Lebrun AL6.*

Fig. 24.

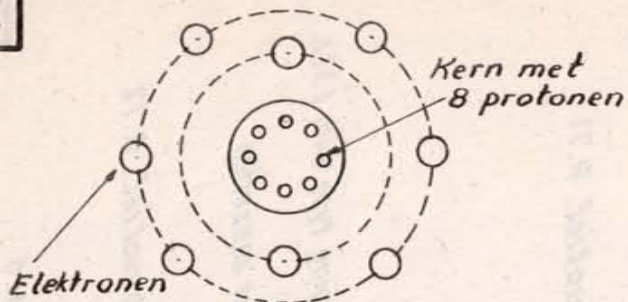

Fig. 25.1.

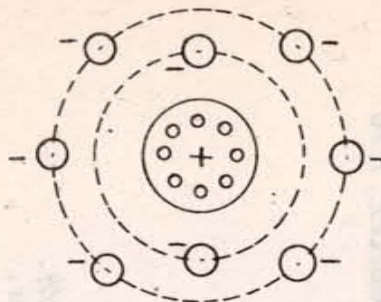

Fig. 25.2.

Waarde + = waarde -

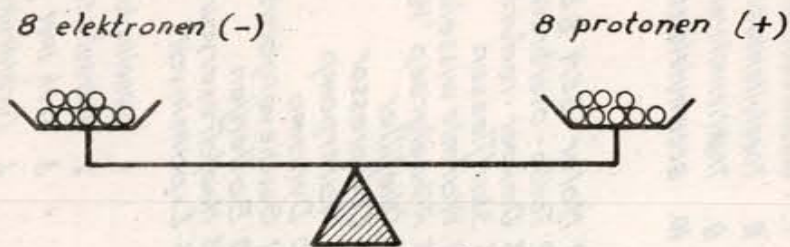

Fig. 25.3.

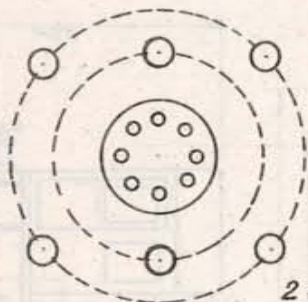

Fig. 25.4.
2 elektronen afgenomen.

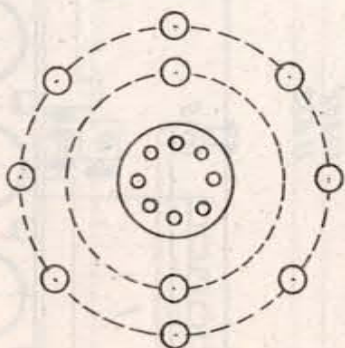
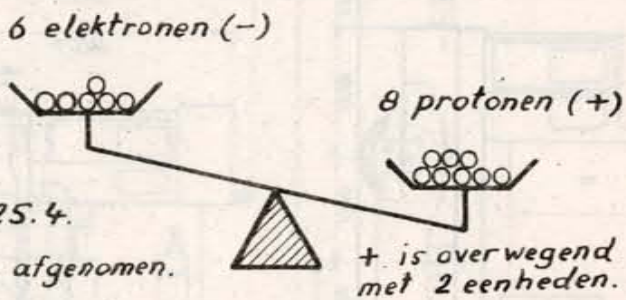

Fig. 25.5.

2 elektronen bijgevoegd.

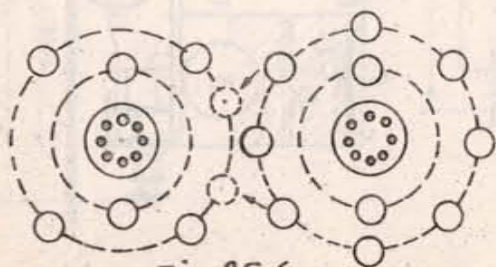
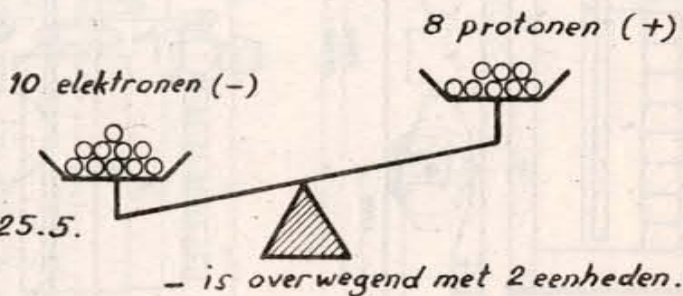

Fig 25.6.

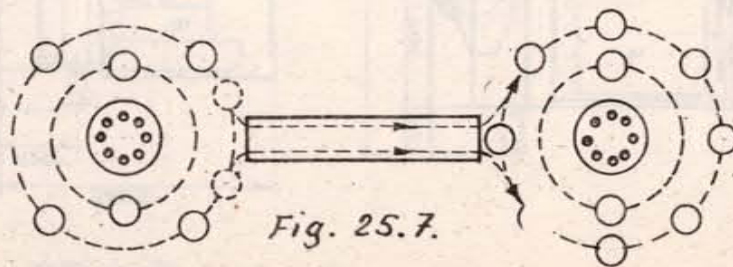
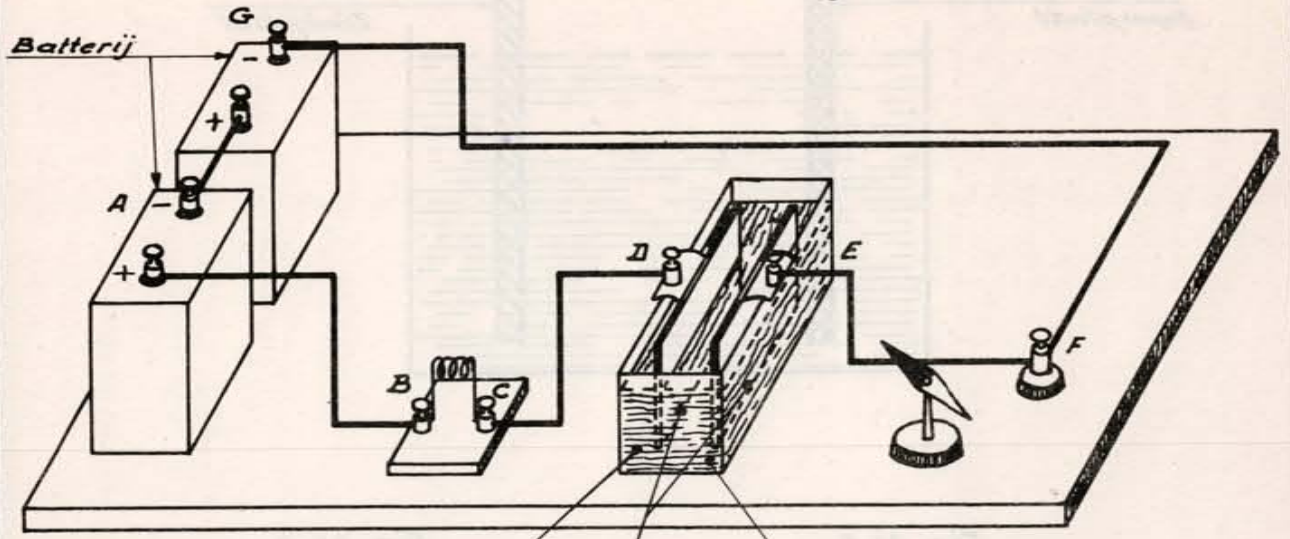

Fig. 25.7.

Fig. 25.8



Glazen bak
Kopersulfaatoplossing.
Koperen platen

Fig. 25.9.

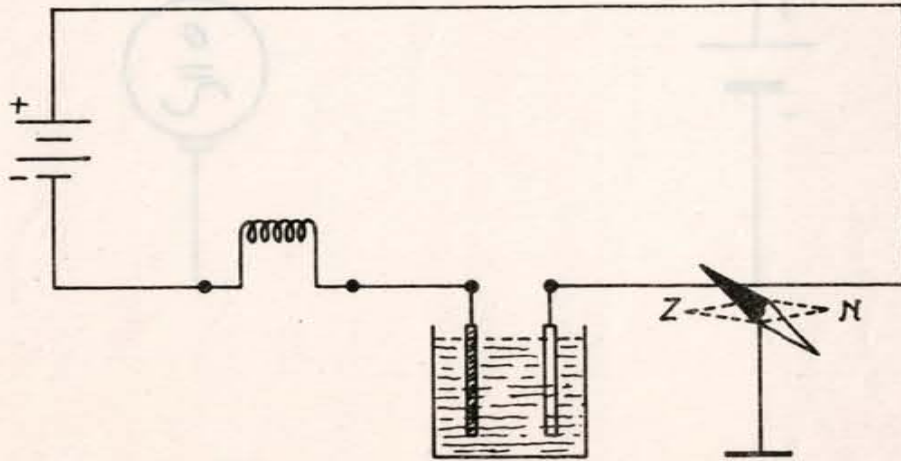

Fig. 25.10

Fig. 25.11.

Fig. 25.12

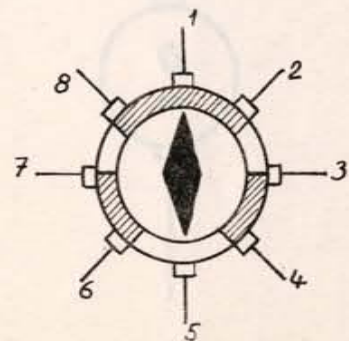
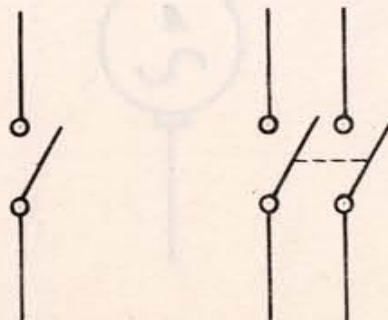

Fig. 26.1.

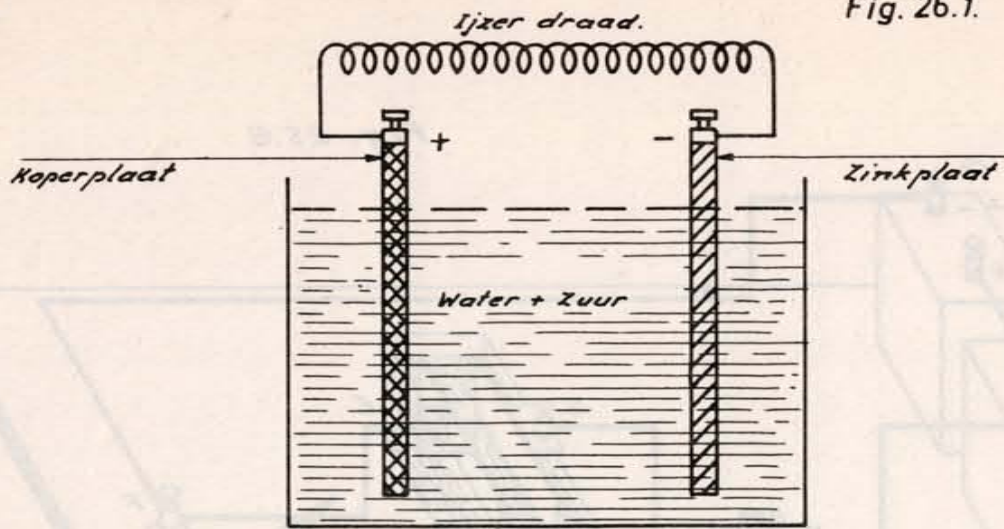

Fig. 26.2

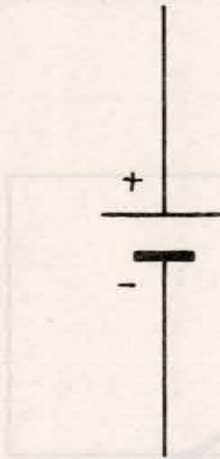

Fig. 26.3

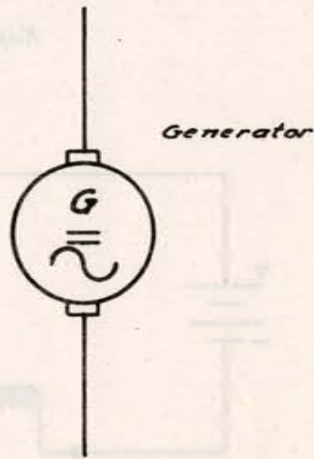

Fig. 26.4

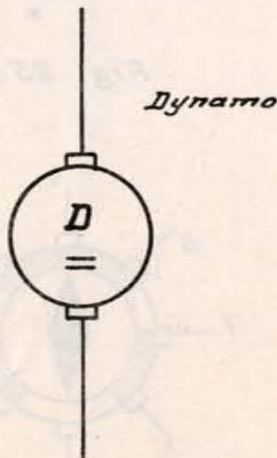

Fig. 26.5

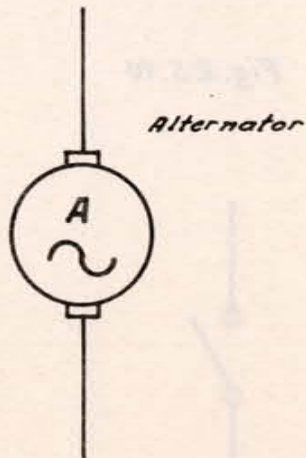

Fig. 27.1

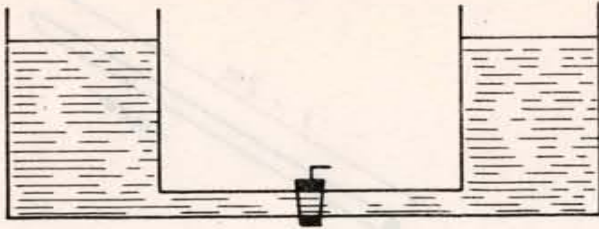

Fig. 27.2

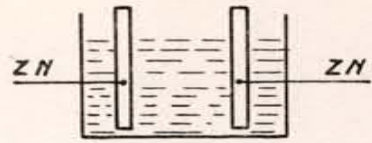

Fig. 27.3

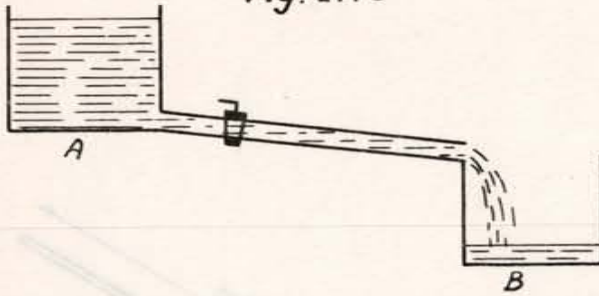

Fig. 27.4

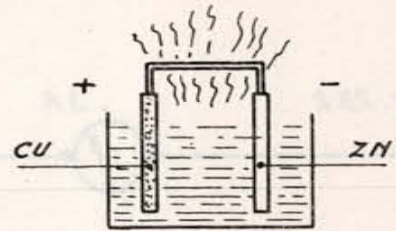

Fig. 27.5

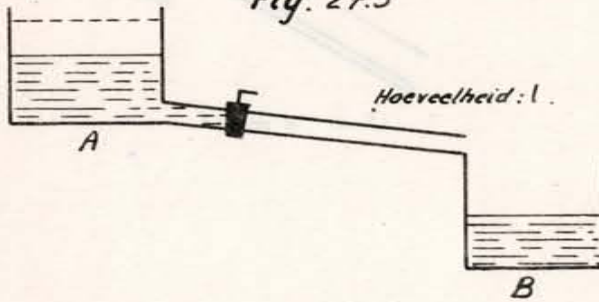

Fig. 27.6

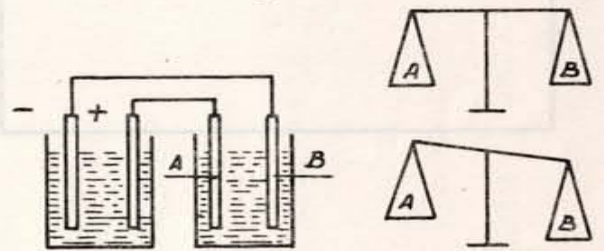

Fig. 27.7

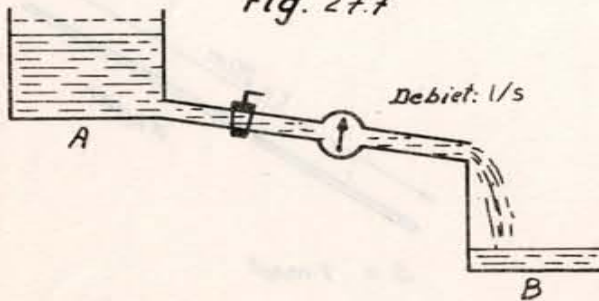

Fig. 27.8

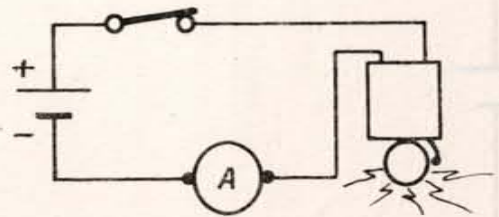

Fig. 27.9

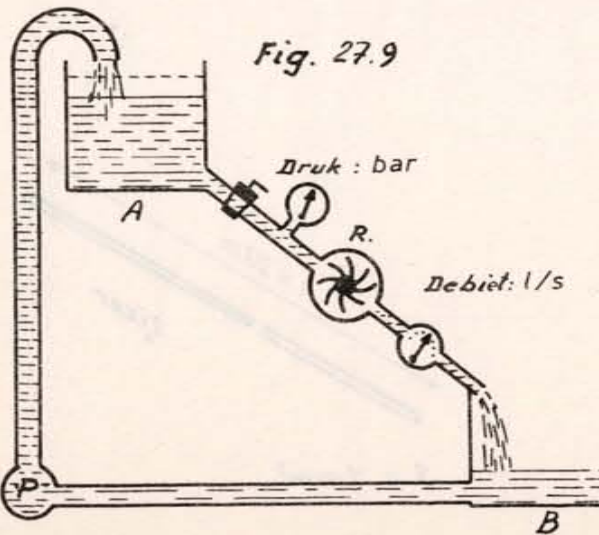
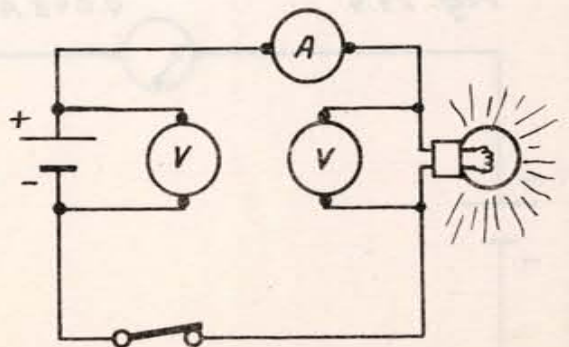

Fig. 27.10



F. 29.1.

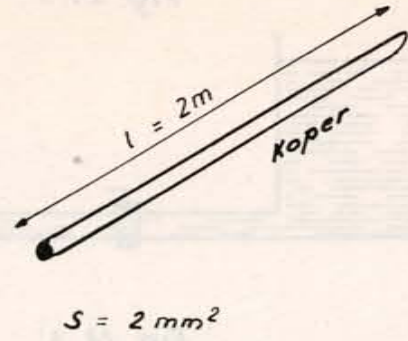
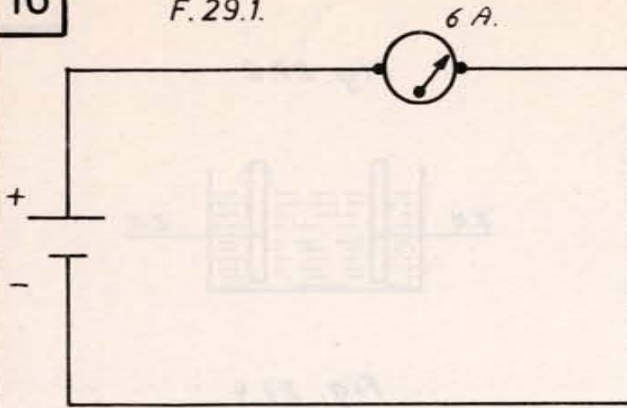

Fig. 29.2

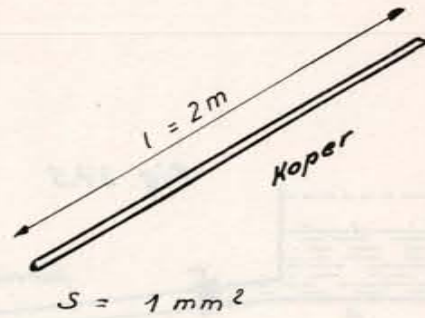
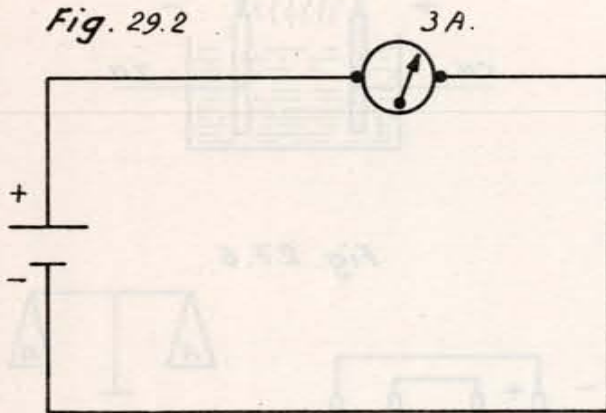

Fig. 29.3

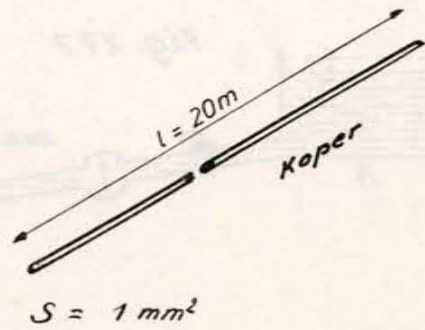
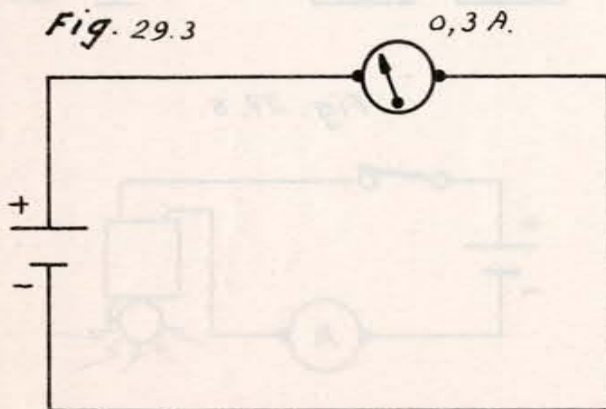
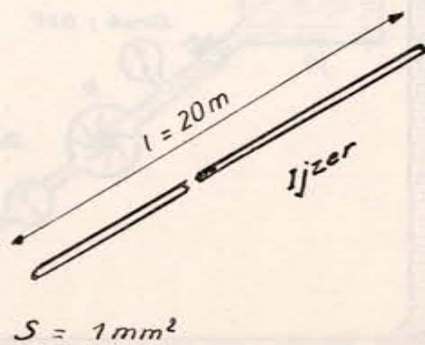
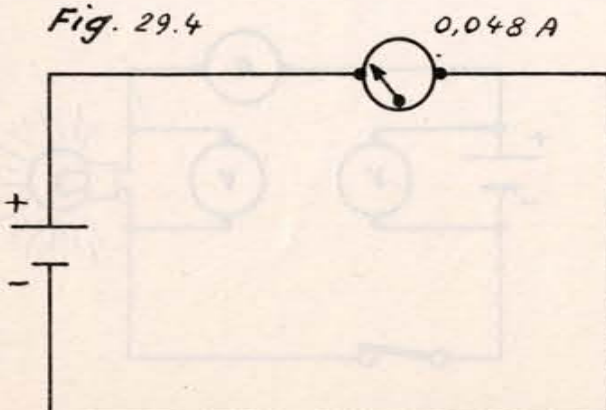

Fig. 29.4



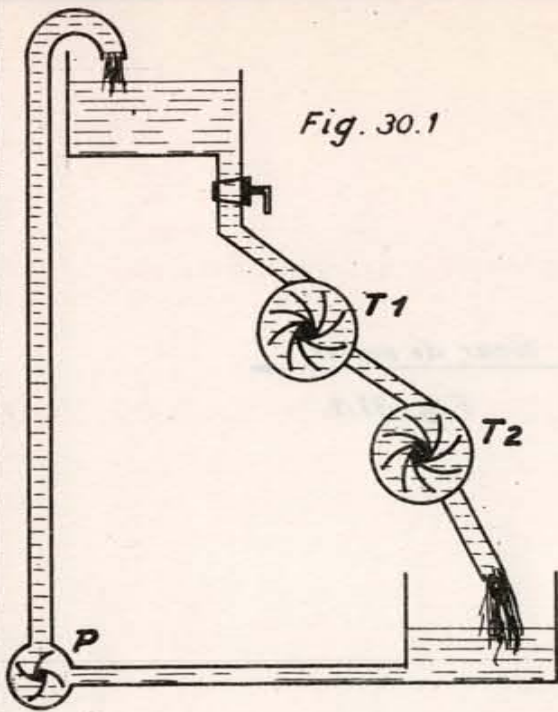

Fig. 30.1

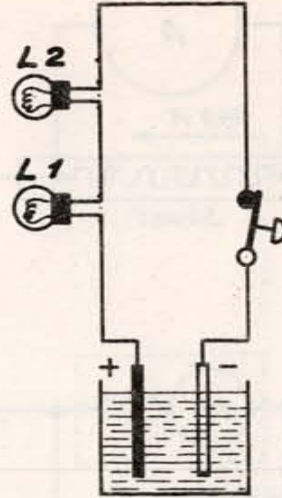

Fig. 30.2

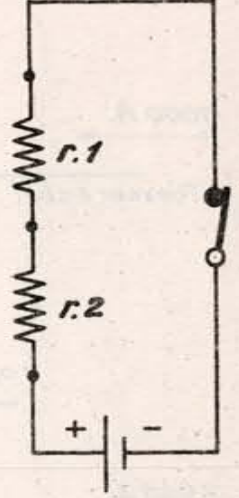

Fig. 30.3

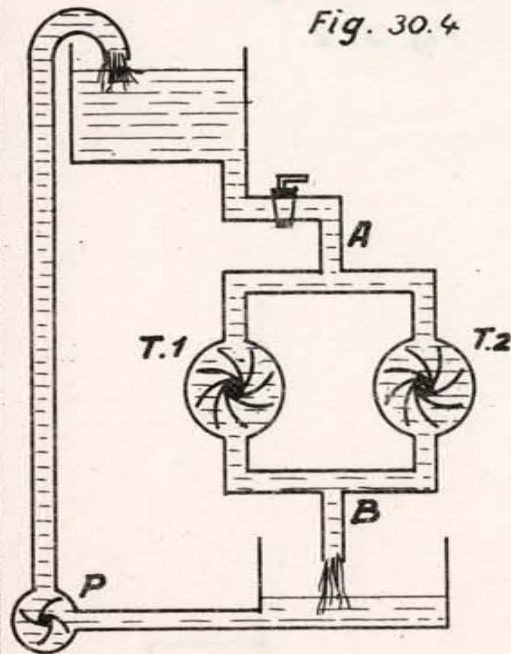

Fig. 30.4

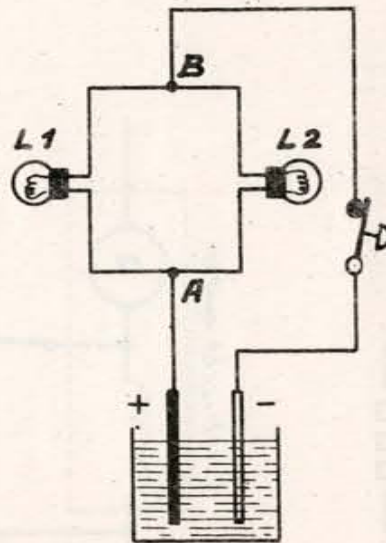

Fig. 30.5

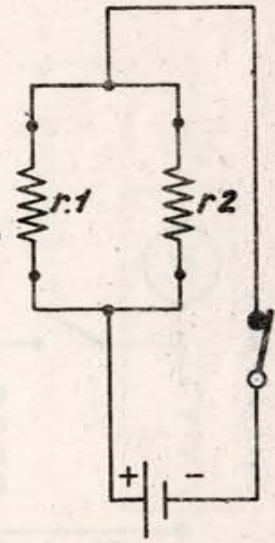

Fig. 30.6

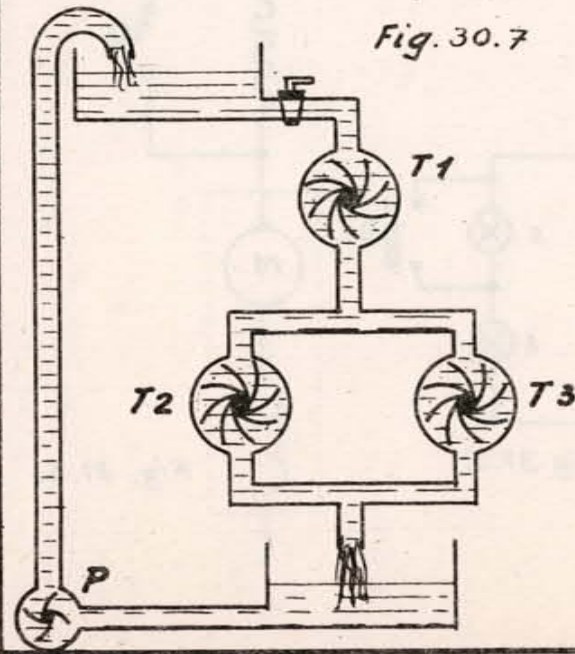

Fig. 30.7

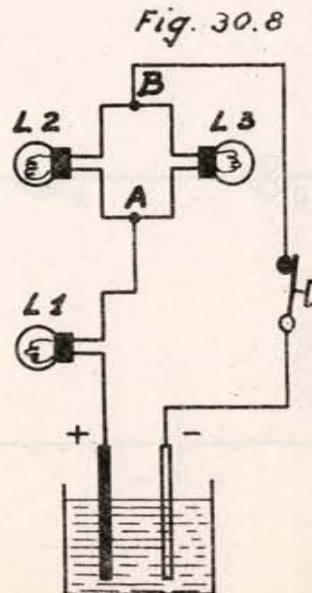

Fig. 30.8

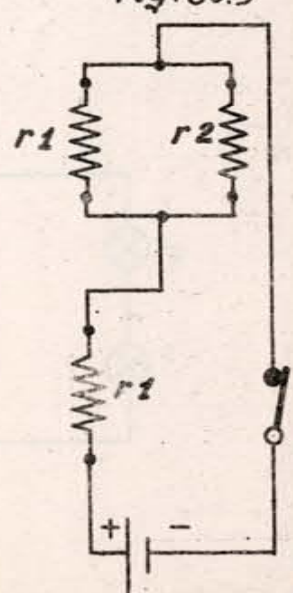
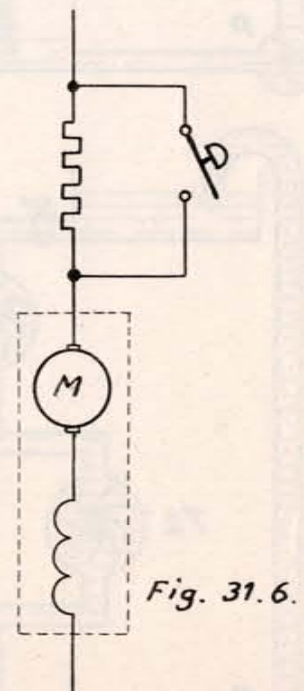
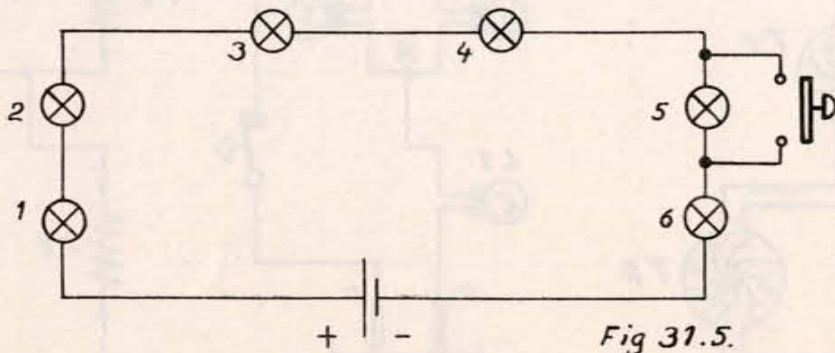
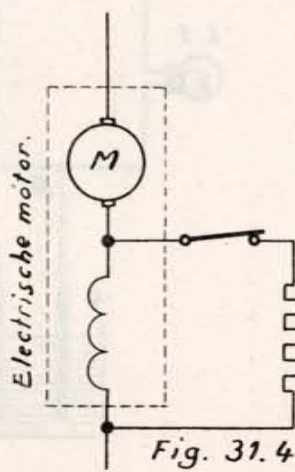
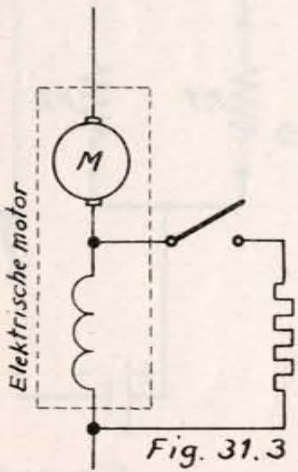
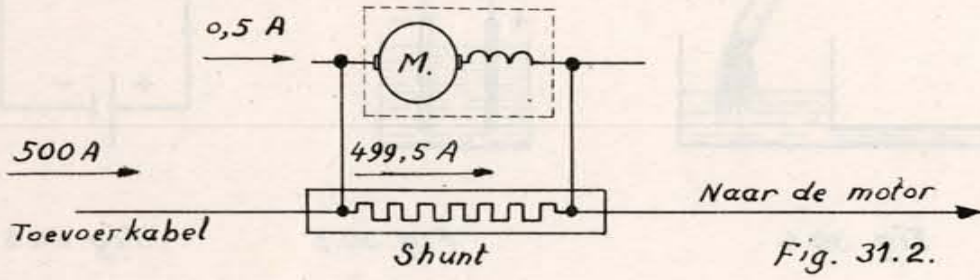
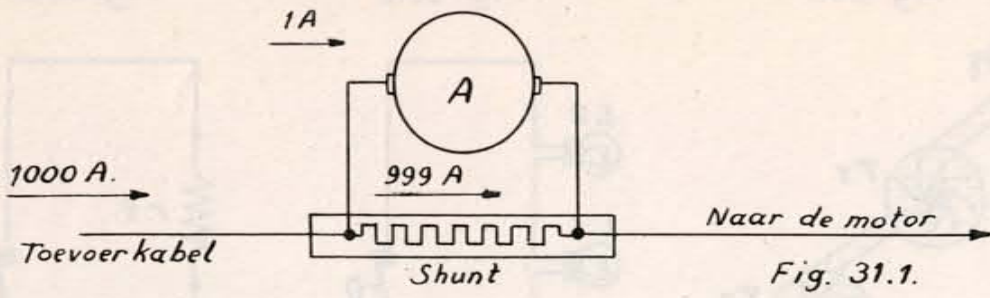
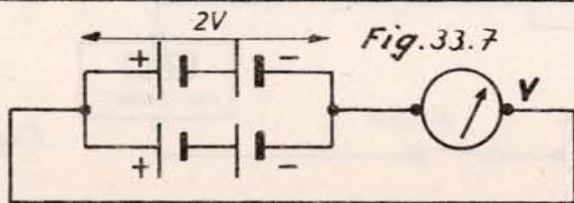
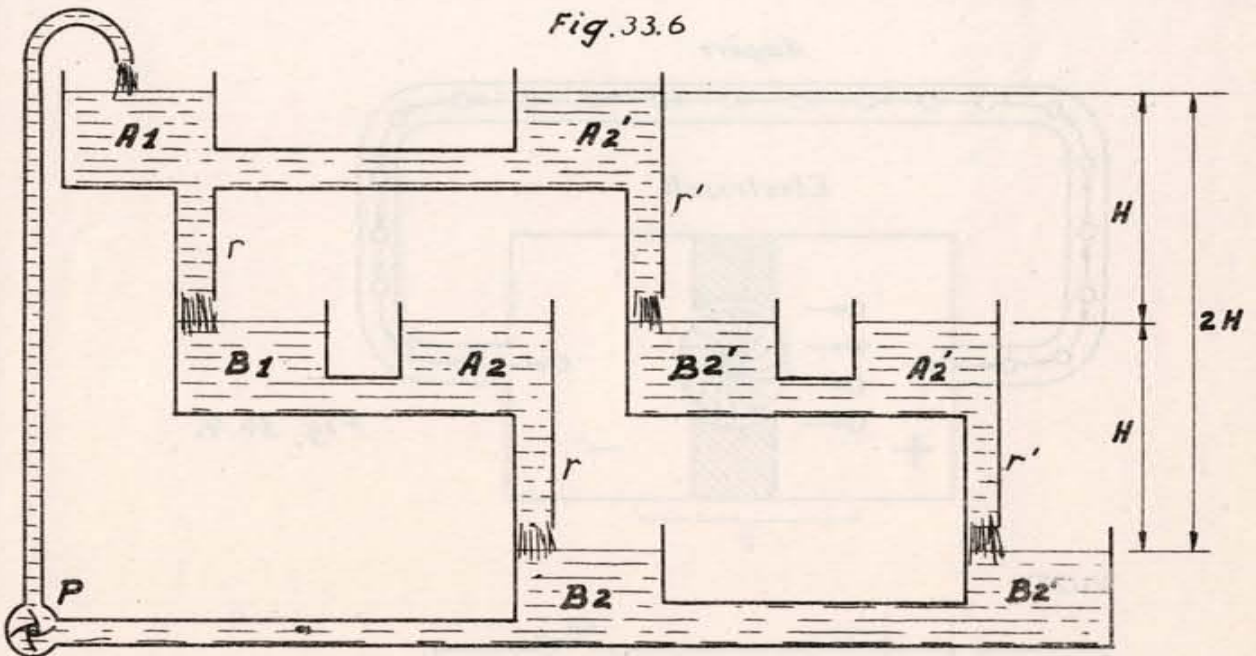
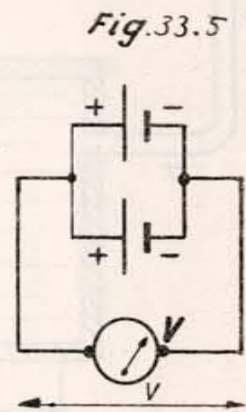
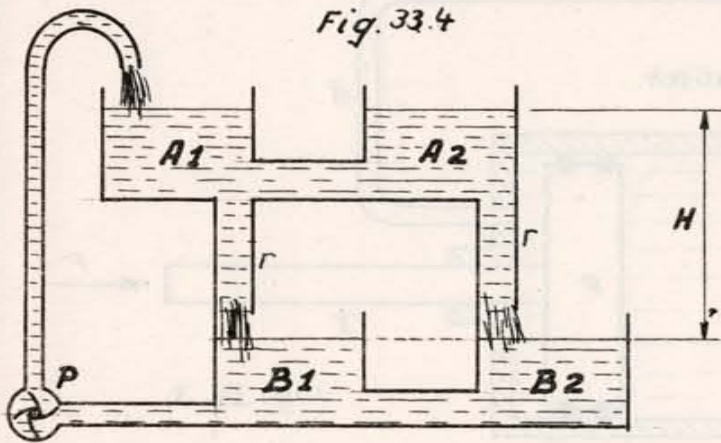
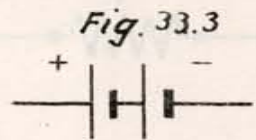
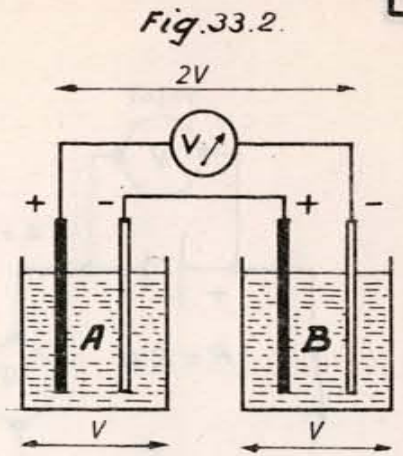
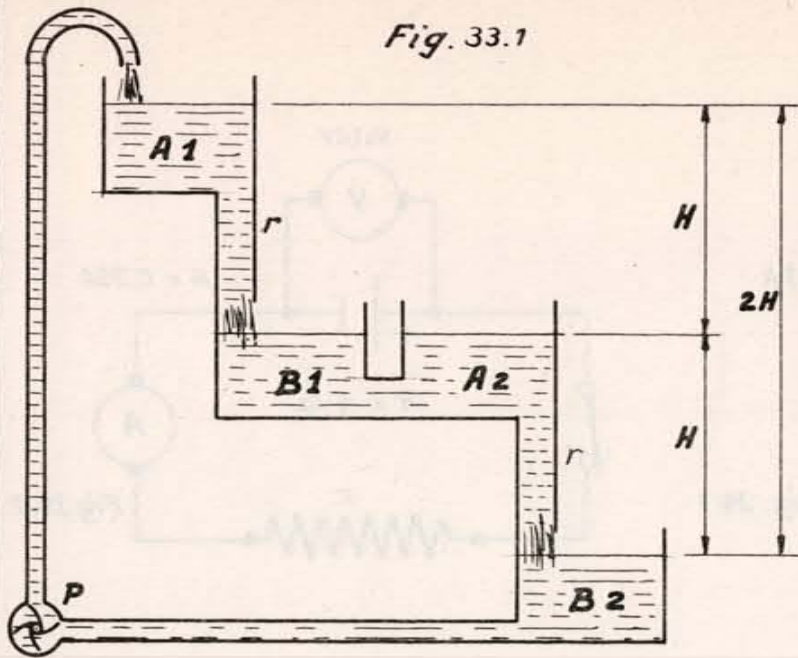

Fig. 30.9





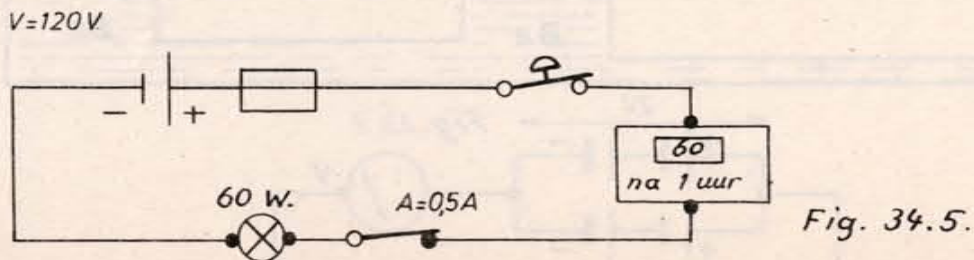
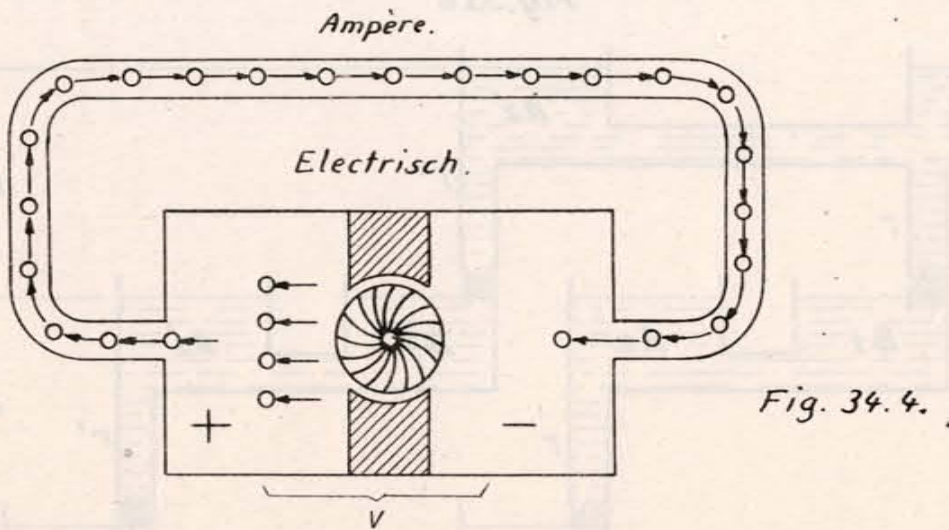
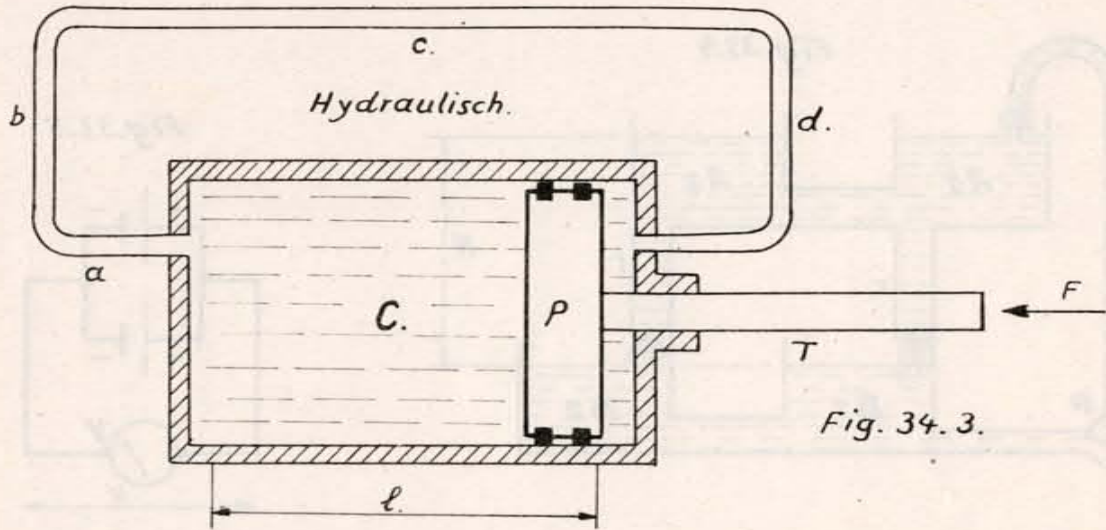
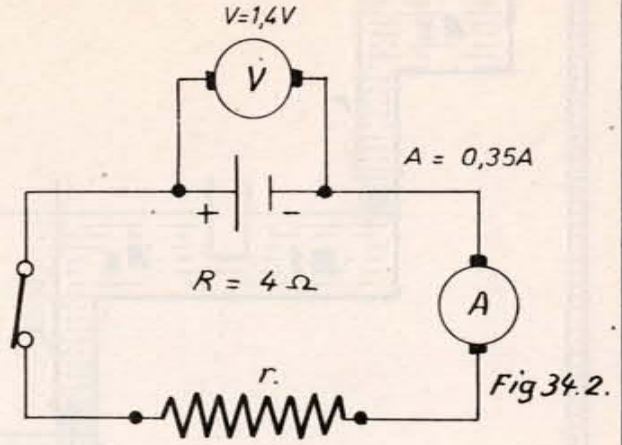
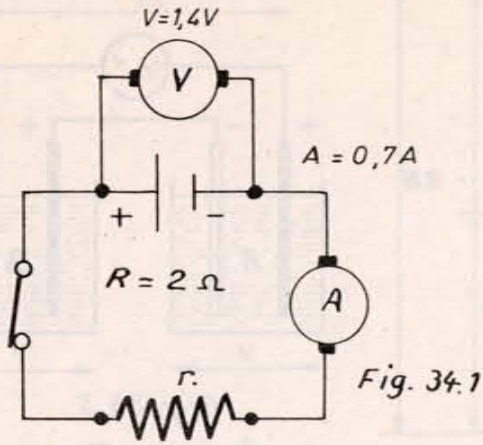

Fig. 35.1

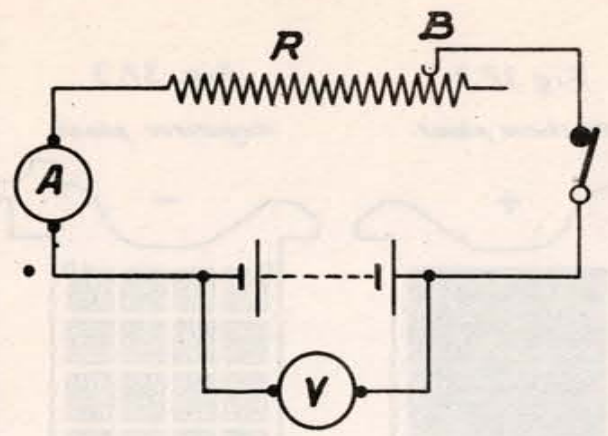

Fig. 35.2

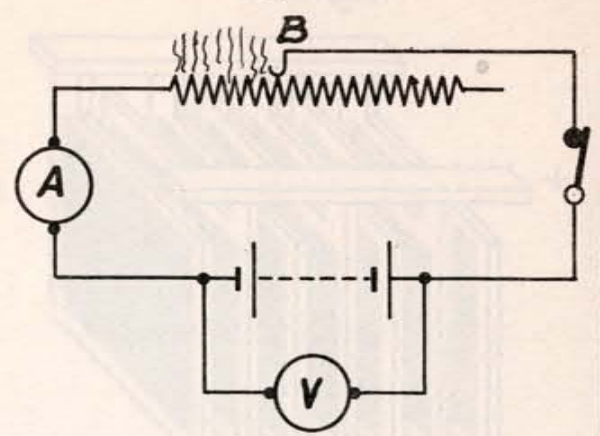

Fig. 35.3

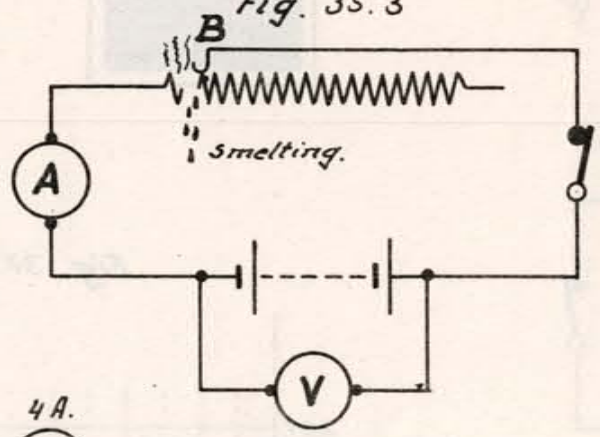

Fig. 35.4

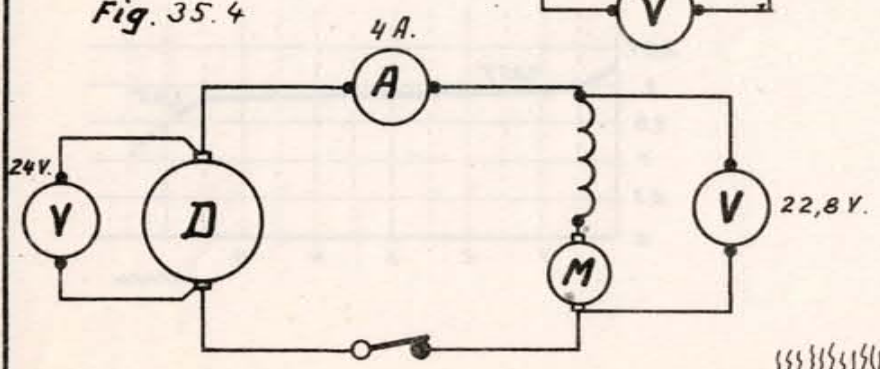

Fig. 35.5

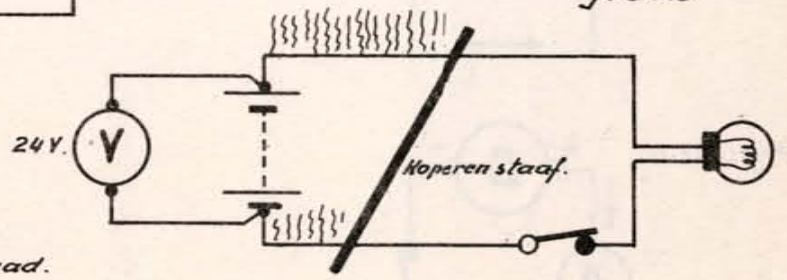

Fig. 35.6

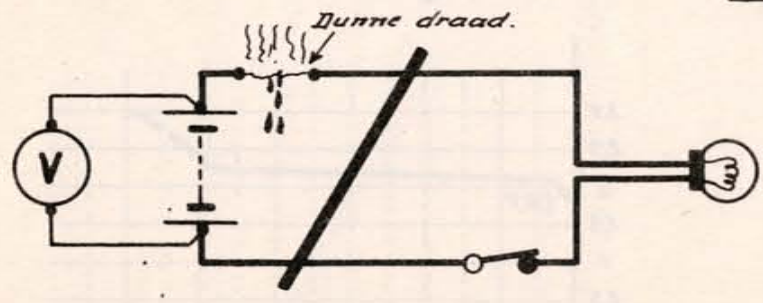

Fig. 35.7



Fig. 37.1

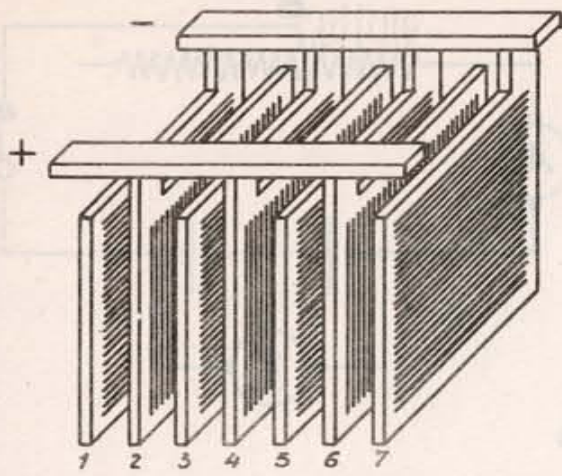

Fig 37.2

Positieve plaat.

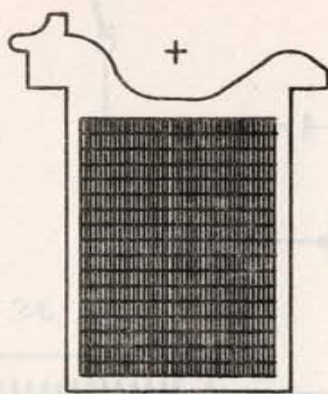

Fig. 37.3

Negatieve plaat.

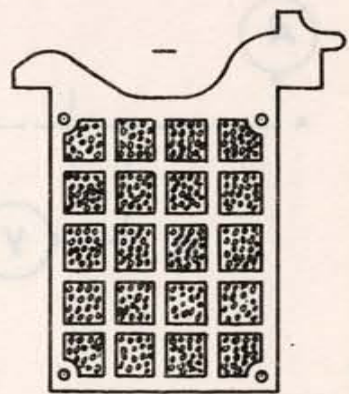

Fig. 37.4

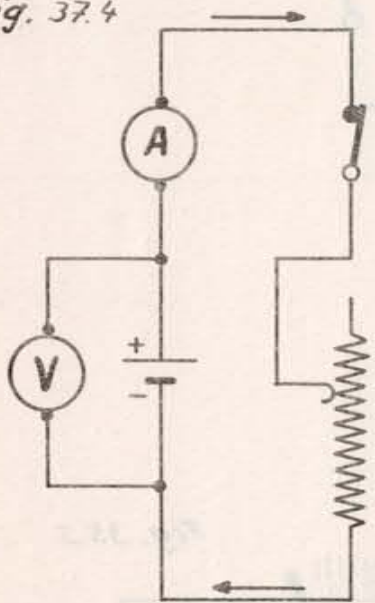

Fig. 37.5

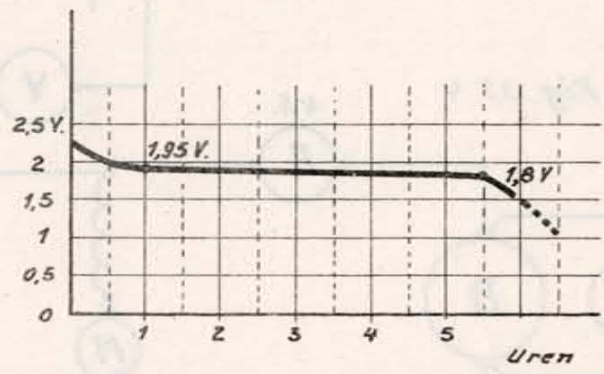

Fig. 37.6

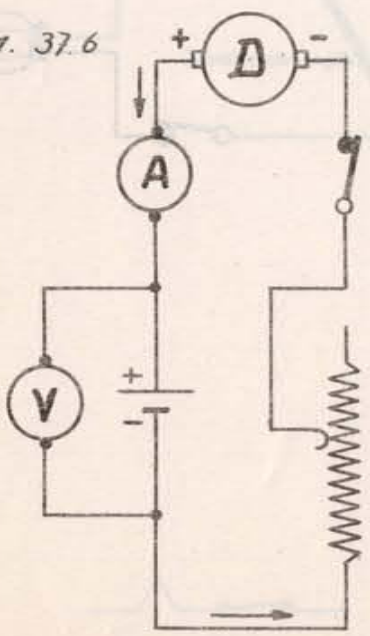
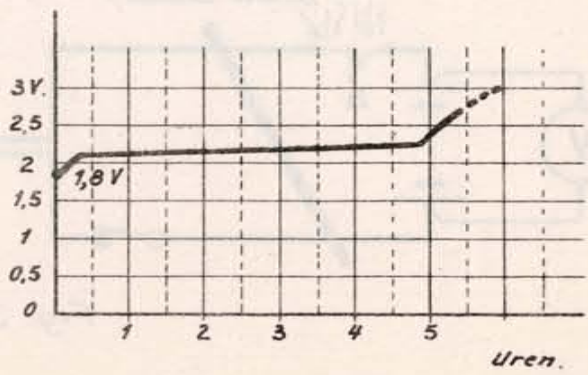

Fig. 37.7.



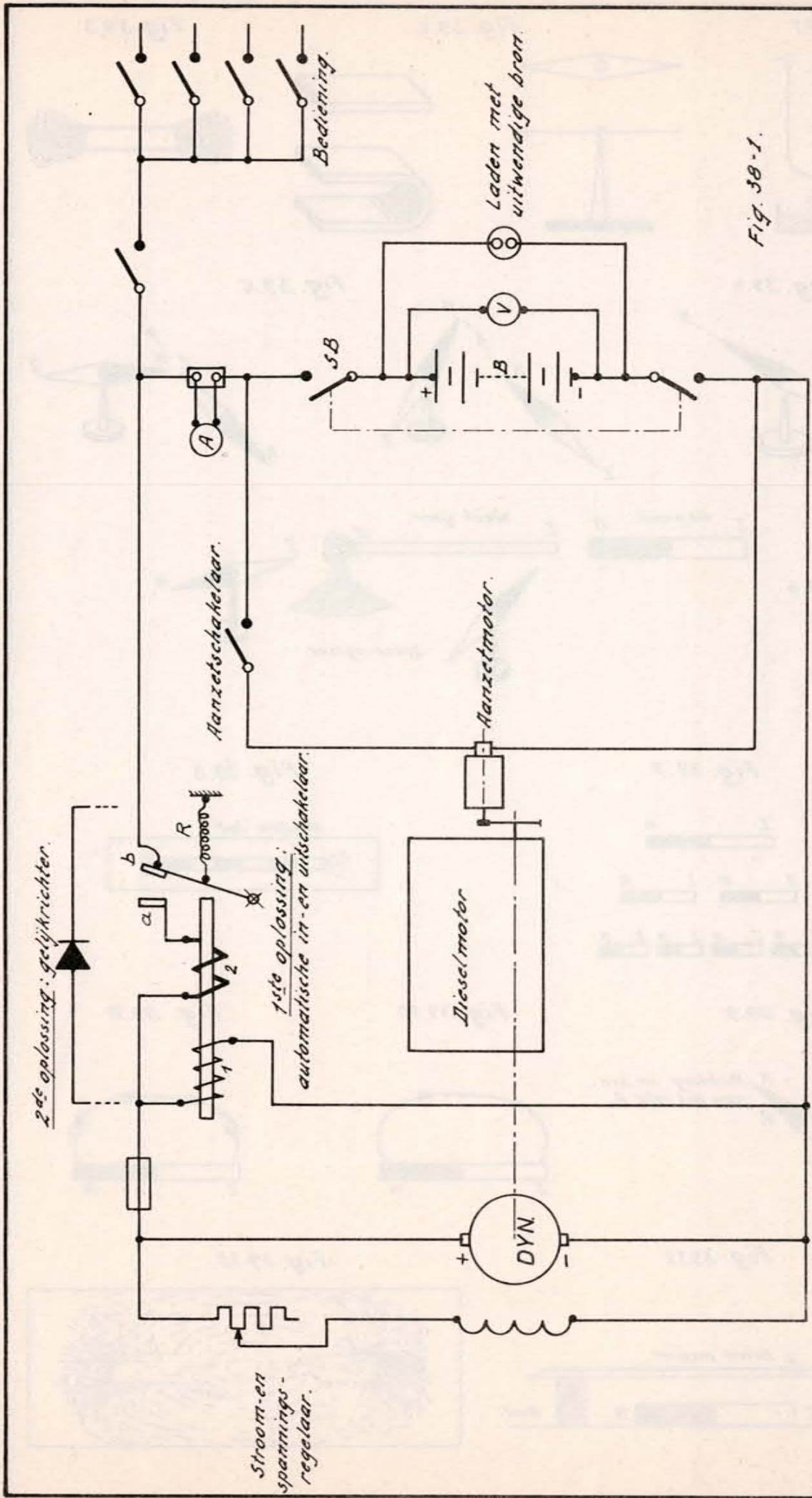

Fig. 38-1.

Stroomkring voor batterijlading.

Fig. 39.1

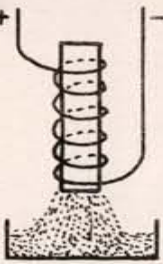

Fig. 39.2

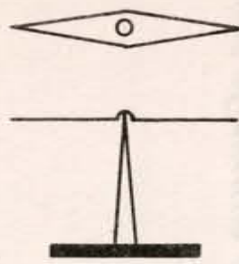

Fig. 39.3

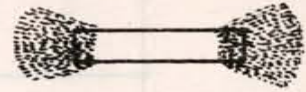

Fig. 39.4



Fig. 39.5

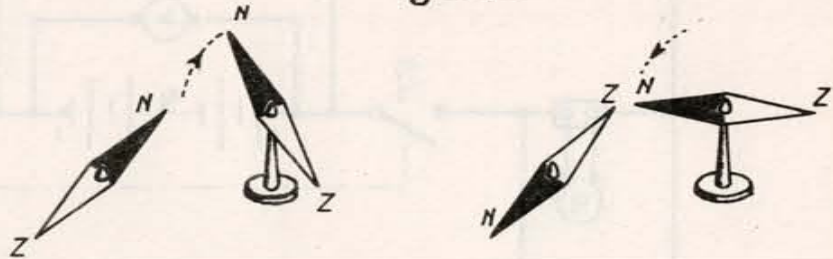

Fig. 39.6

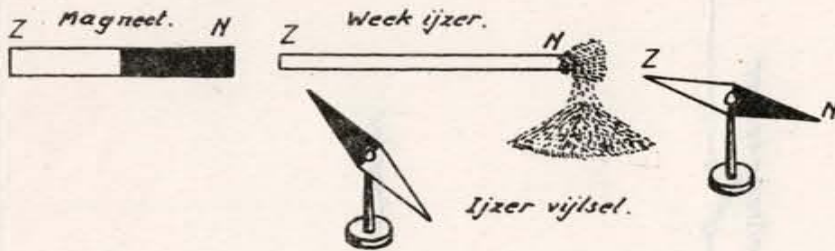

Fig. 39.7

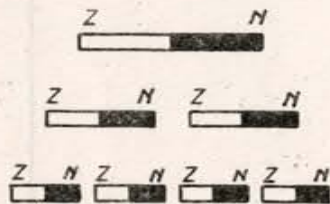

Fig. 39.8

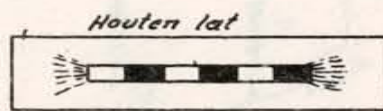

Fig. 39.9



Fig. 39.10

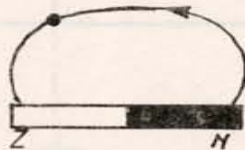

Fig. 39.11

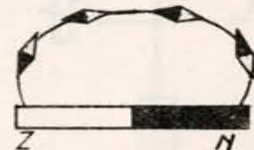

Fig. 39.12

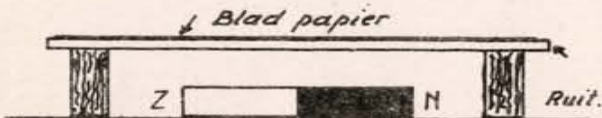

Fig. 39.13



Fig. 41.1

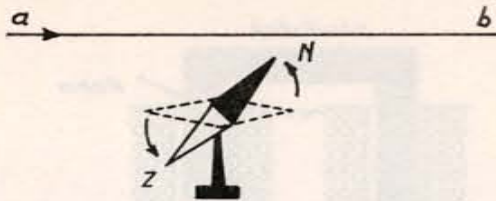

Fig. 41.3

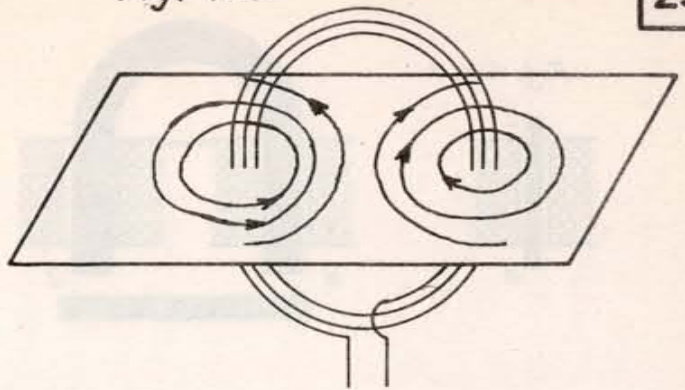

Fig 41.2

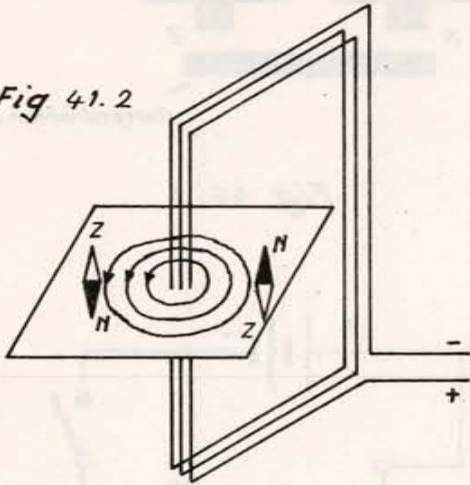

Fig. 41.4

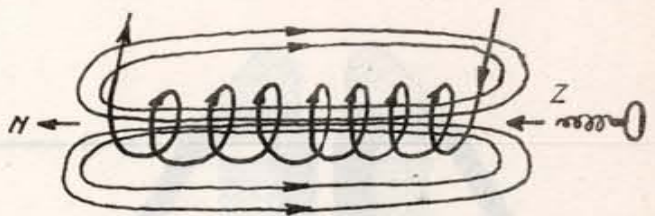

Fig. 41.6

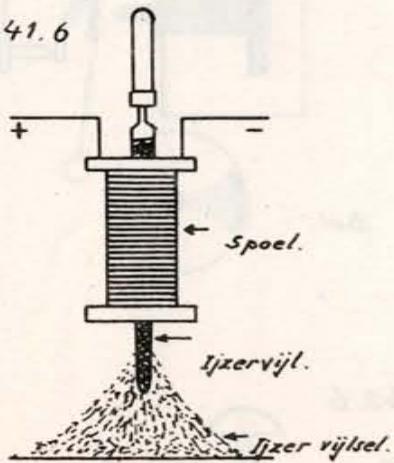

Fig. 41.5

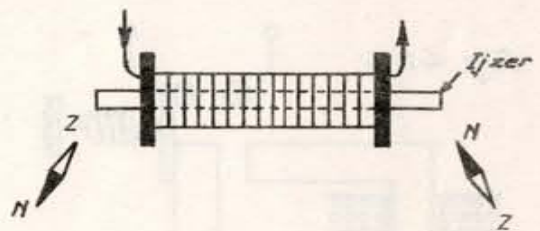

Fig. 41.7

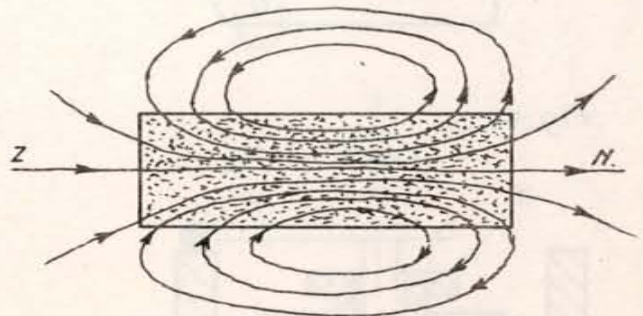

Fig. 41.8

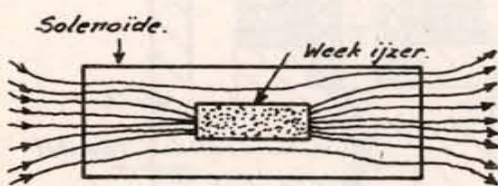

Fig. 41.9

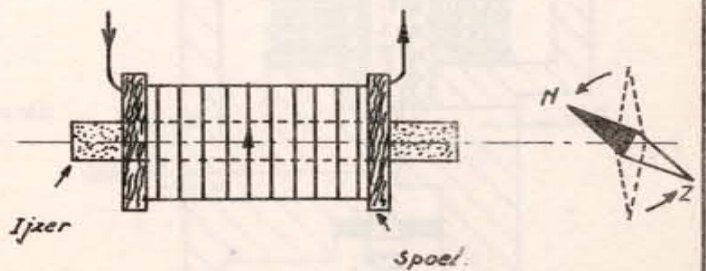

Fig. 42.1.

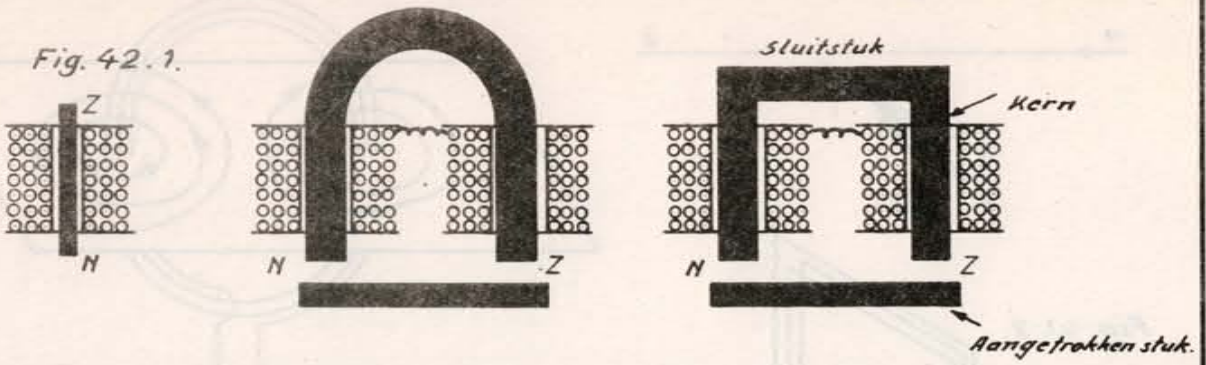

Fig. 42.2.

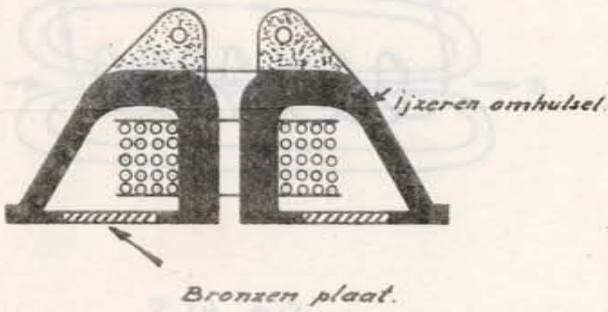

Fig. 42.3

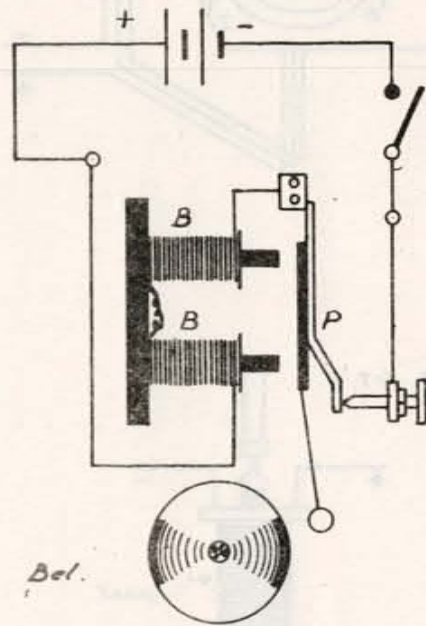

Fig. 42.4.

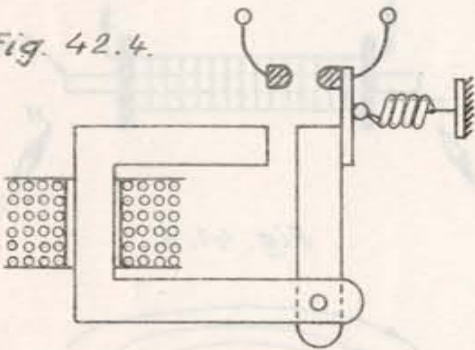

Fig. 42.5.

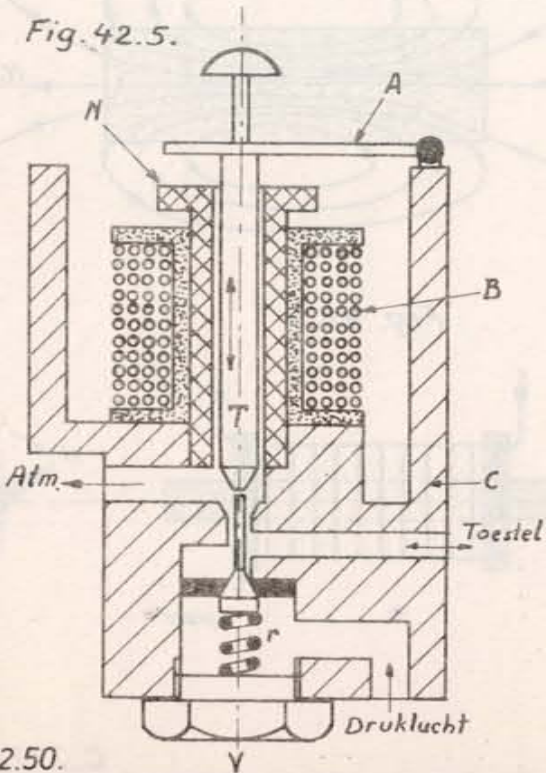

Fig. 42.6

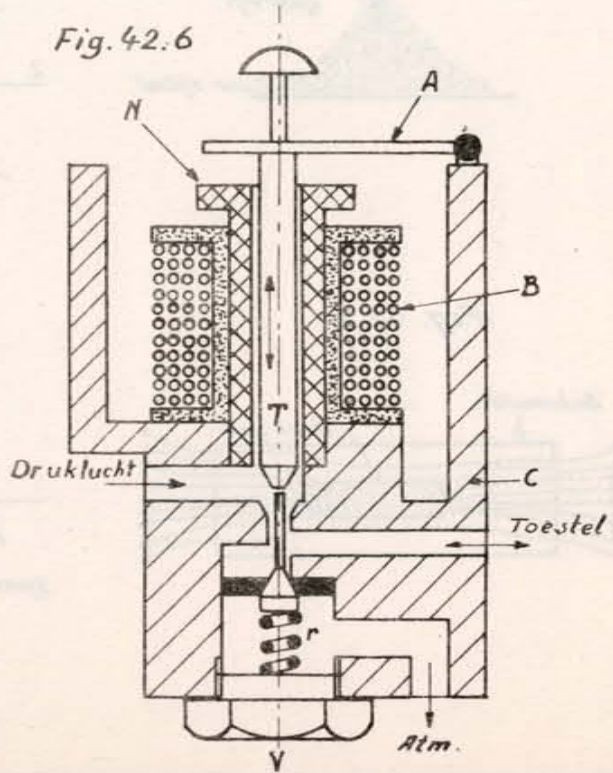

Fig. 43.1

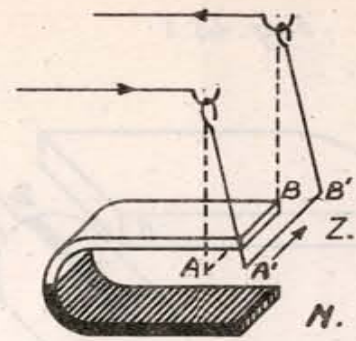
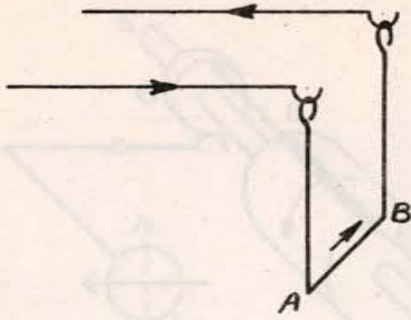

Fig. 43.3

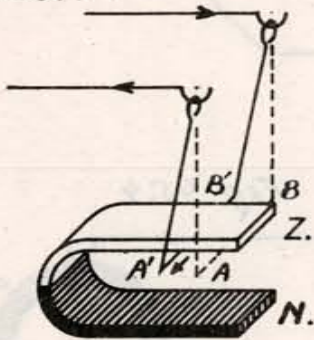

Fig. 43.4

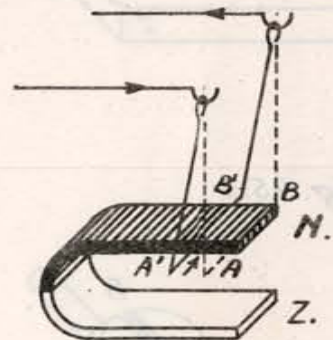

Fig. 43.5

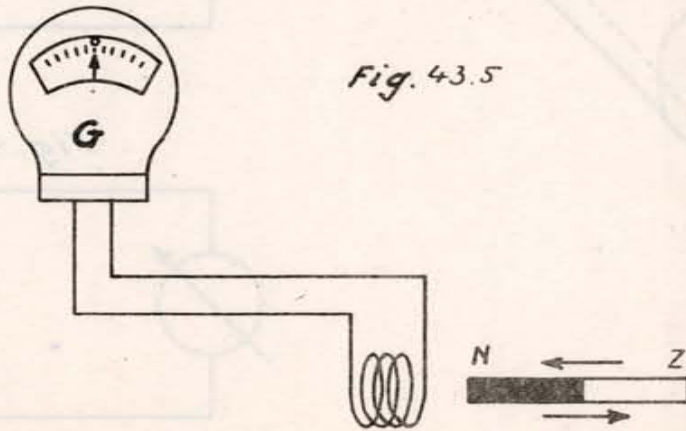

Fig. 43.6

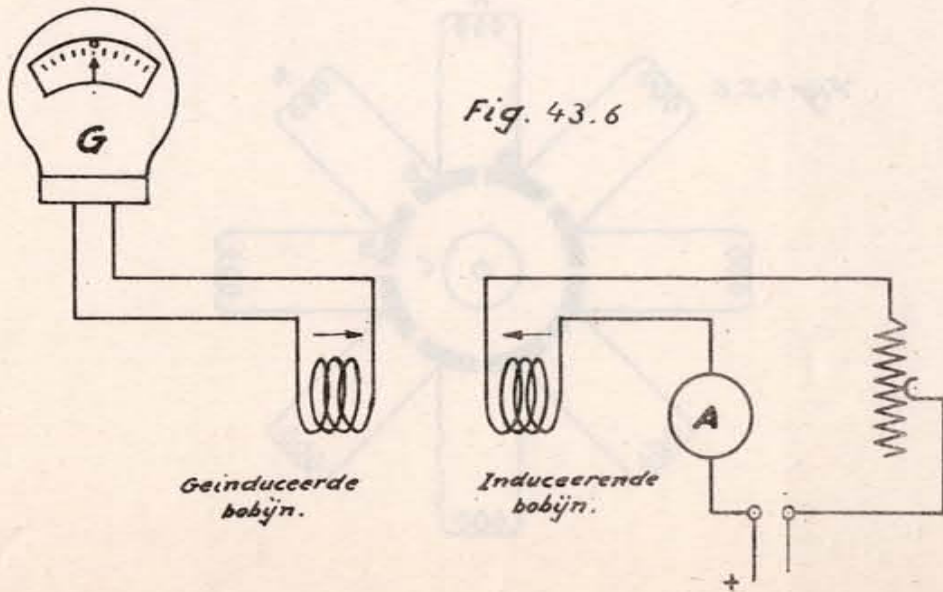

Fig. 45.1

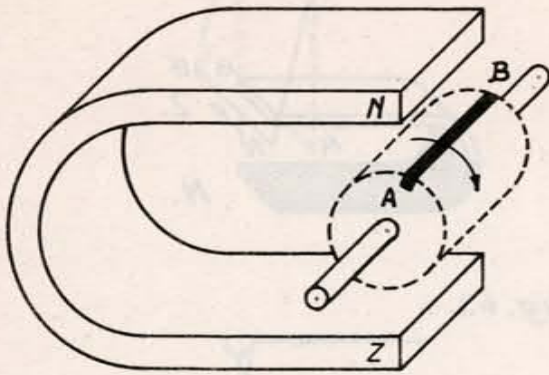

Fig. 45.2

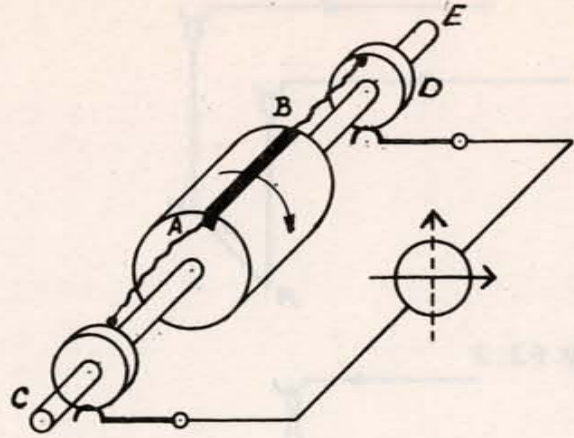

Fig. 45.3

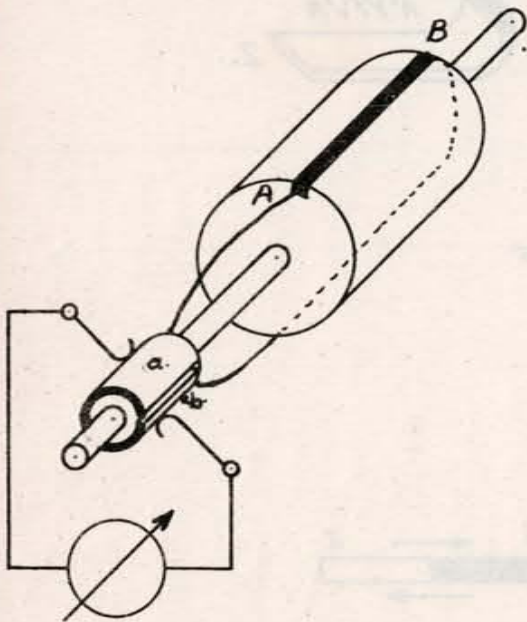

Fig. 45.4

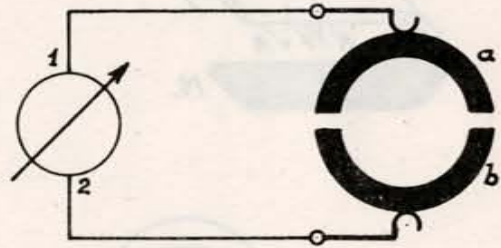

Fig. 45.5

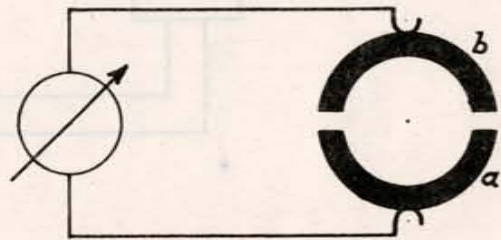

Fig. 45.6

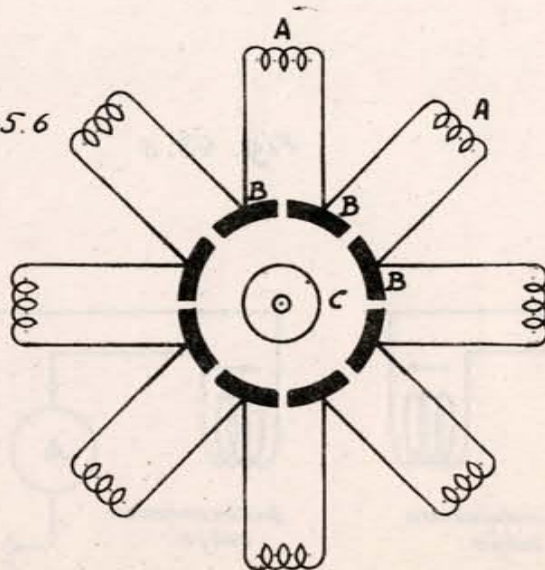

Fig. 45.7

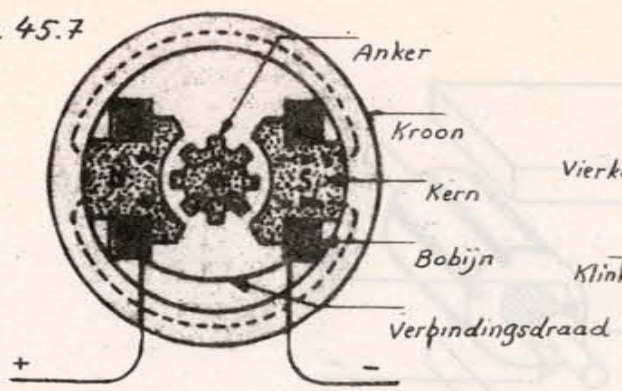

Fig. 45.8

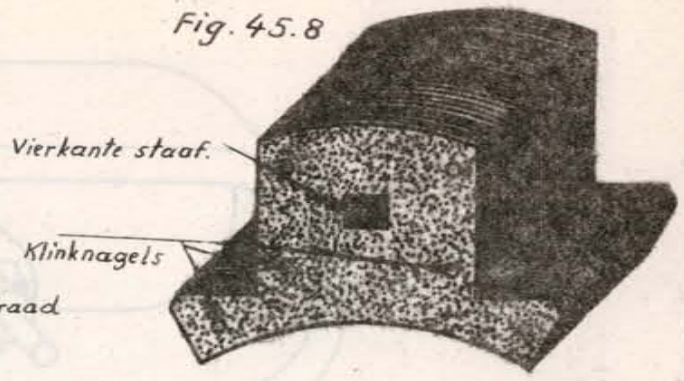

Fig. 45.9.

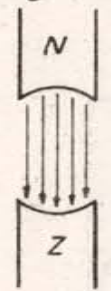

Fig. 45.10.

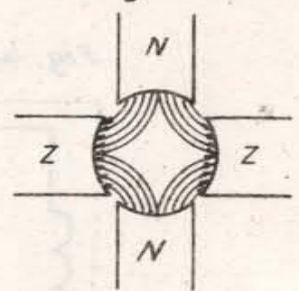

Fig. 45.11.

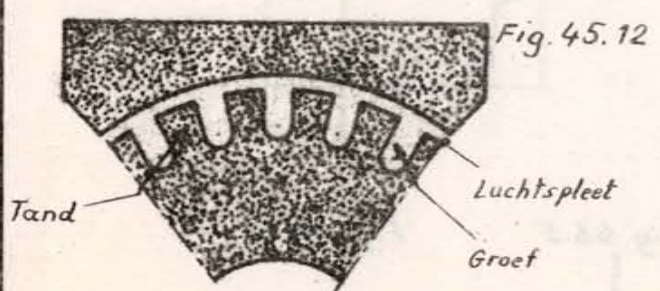
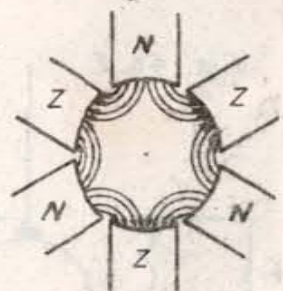
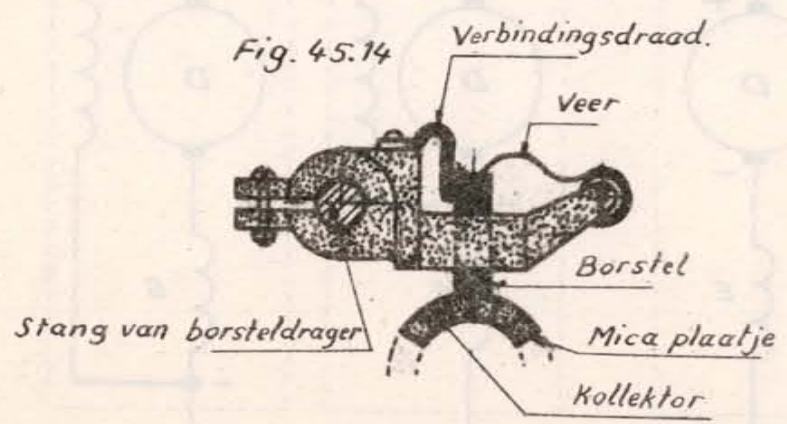

Fig. 45.13



Fig. 45.14



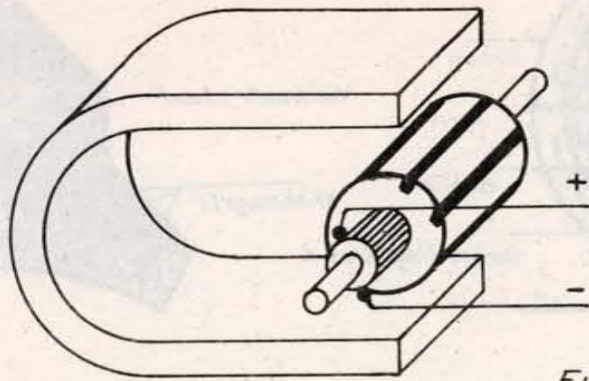

Fig. 46.1.

Fig. 46.2.

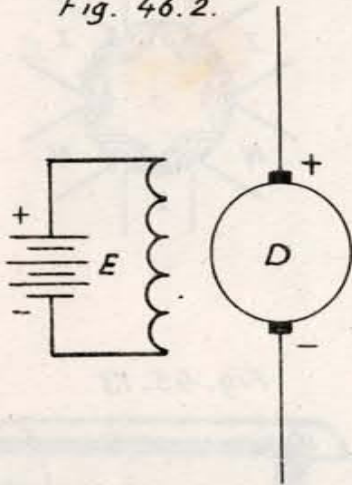

Fig. 46.3

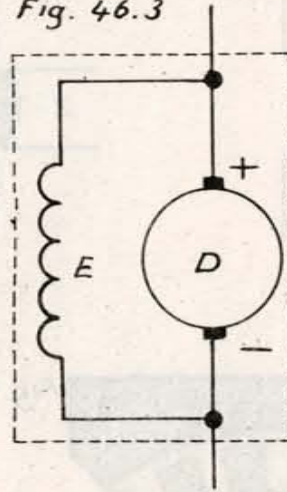

Fig. 46.4.



Fig. 46.5

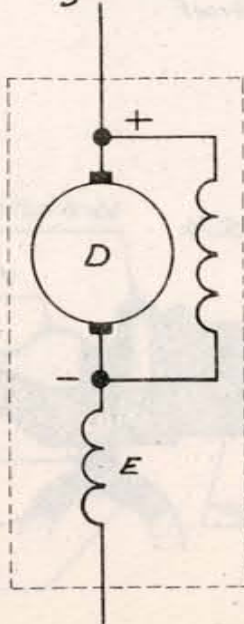

Fig. 46.6.

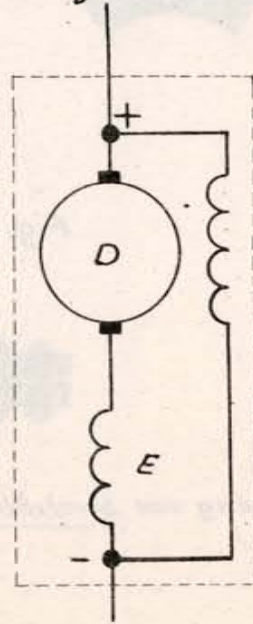

Fig. 47.1



Fig. 47.2

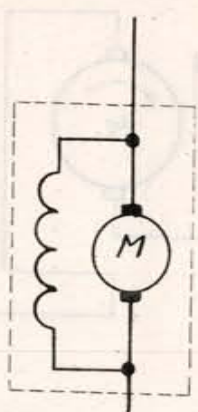

Fig. 47.3

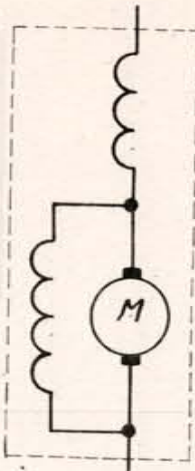
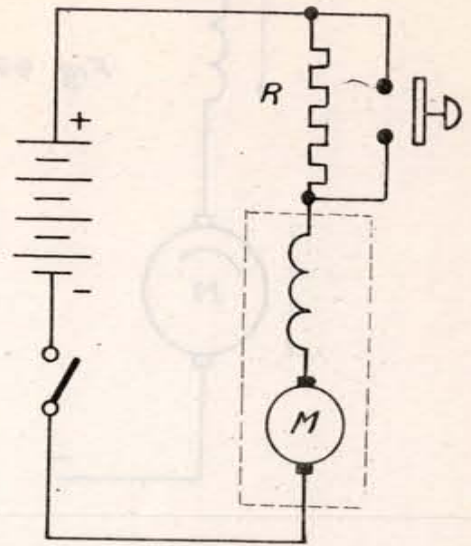

Fig. 47.4.



+

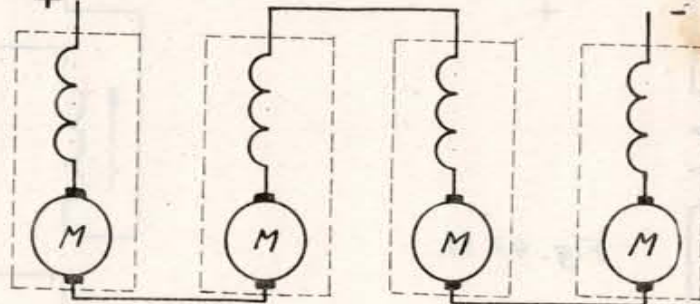

Fig. 47.5.

+

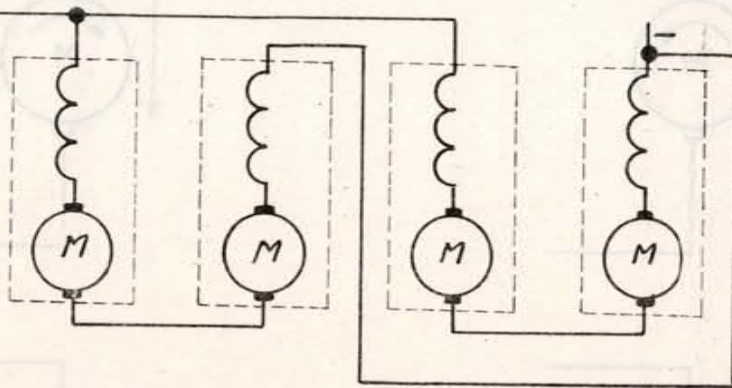
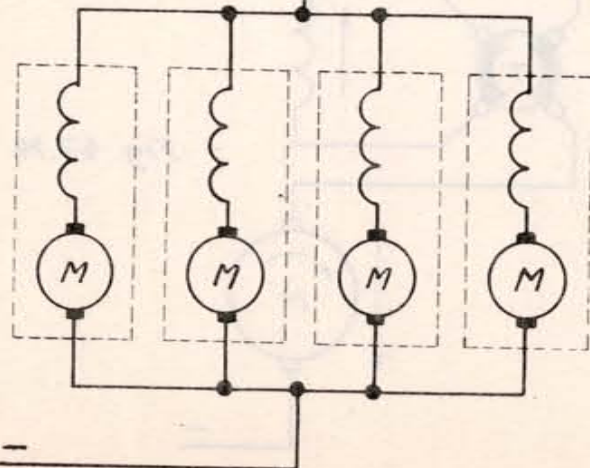

Fig. 47.6.

+

Fig. 47.7



+

Fig. 47.8.

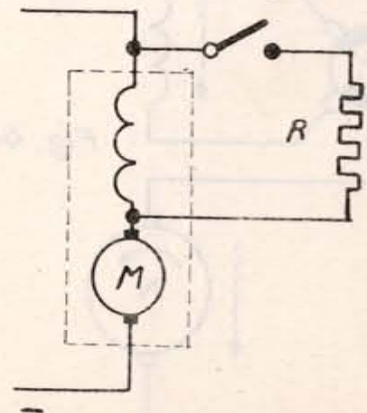

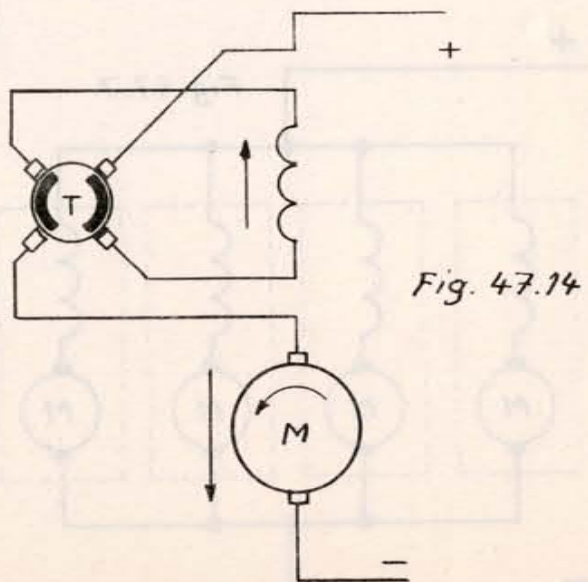
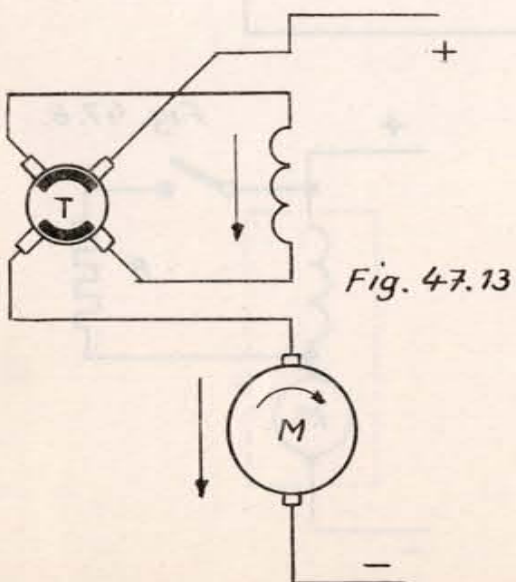
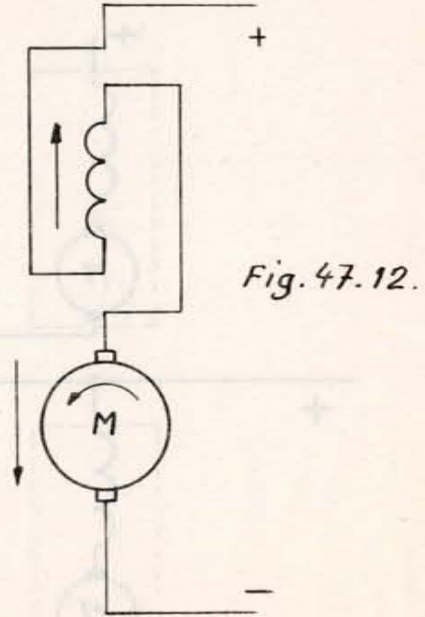
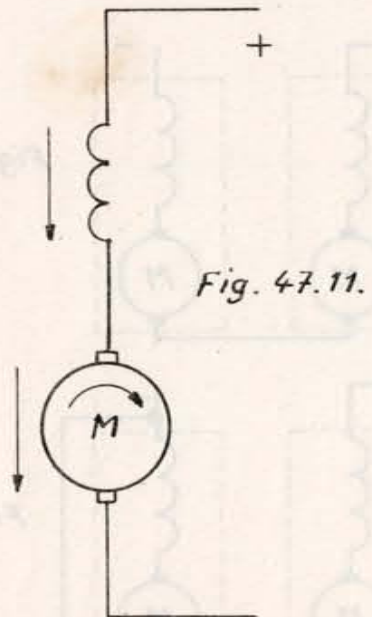
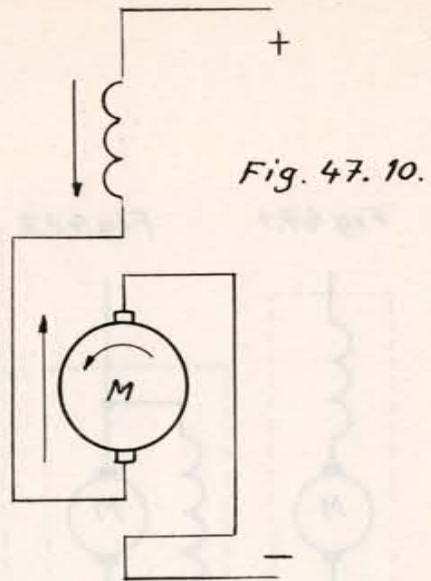
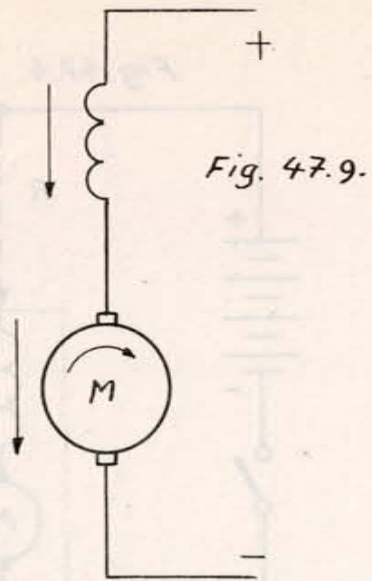

Elektrische symbolen.

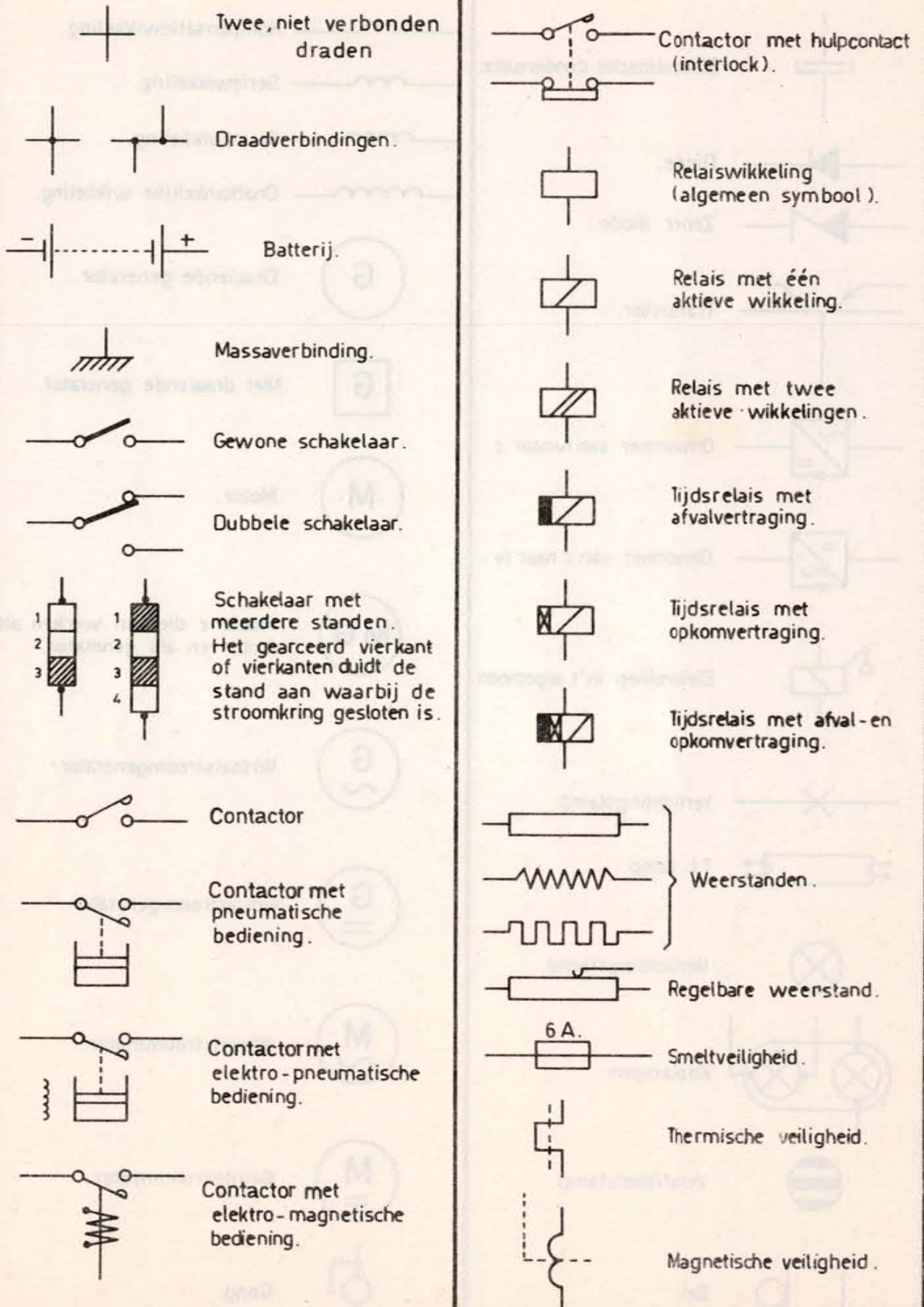

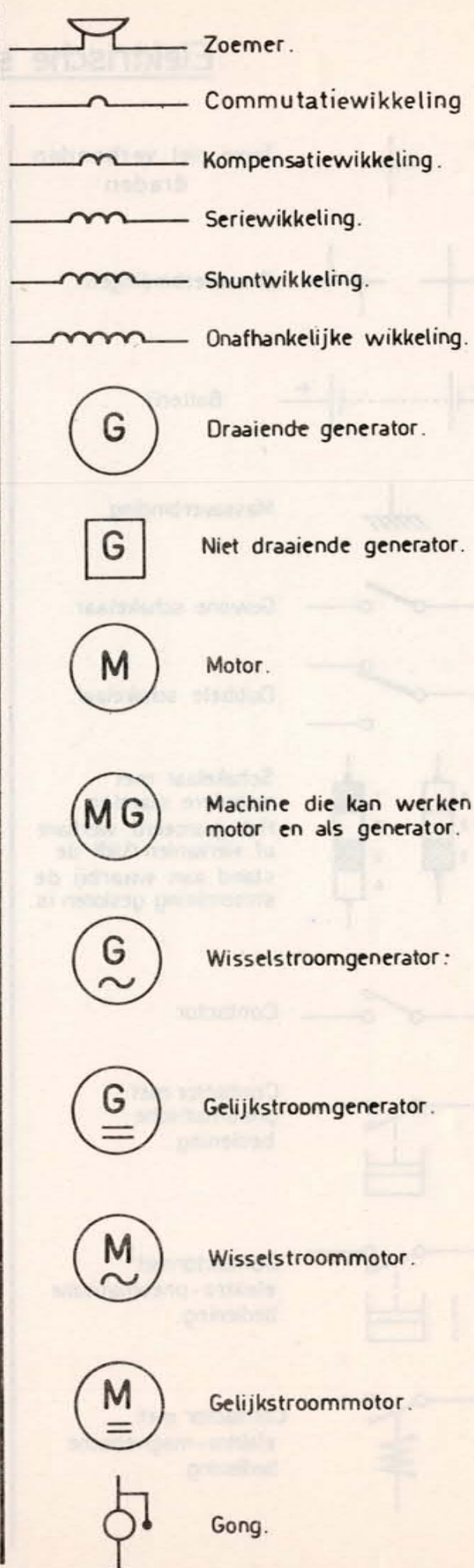
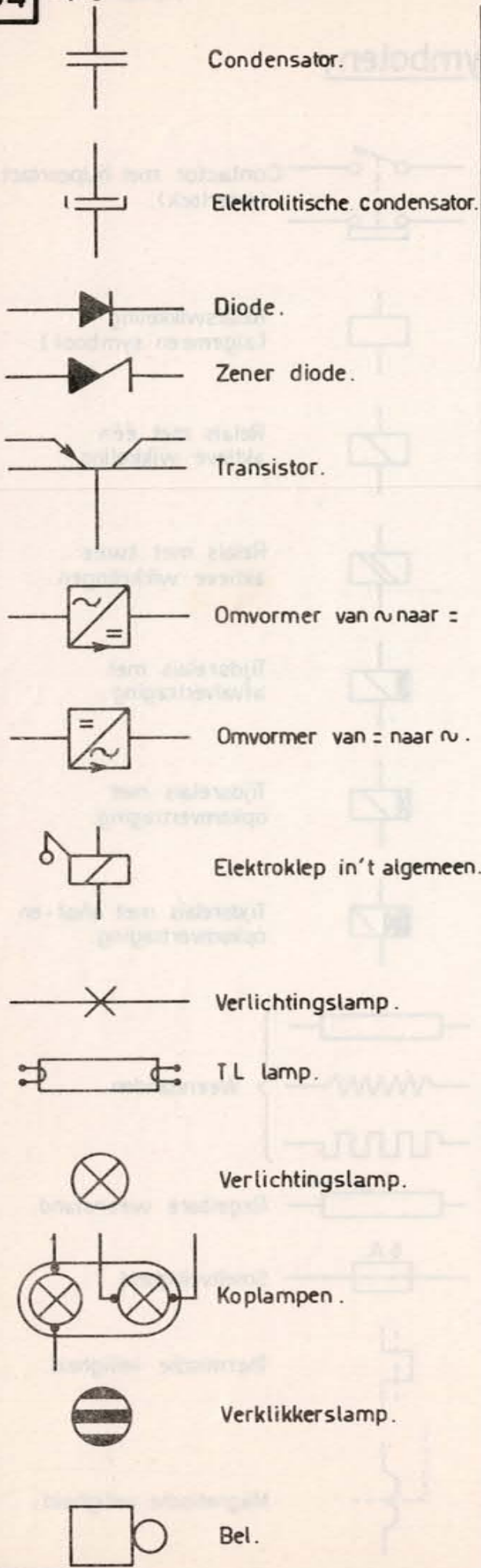



Alternator.



Synchrone motor.



Asynchrone motor.



Tractiemotor.



Hoofdgenerator.



Bekrachtigingsgenerator.



Hulpgenerator.

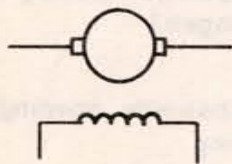

Generator met onafhankelijke bekrachtiging



Serie-motor of dynamo.

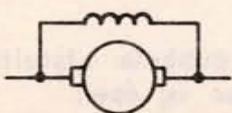

Shunt-motor of dynamo.



Compound-motor of dynamo

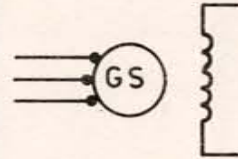

Driefazige wisselstroomgenerator.

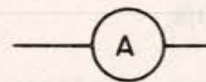

Ampèremeter.

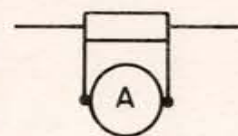

Ampèremeter op shunt.

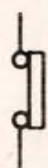

Contact opent wanneer de spoel bekrachtigd wordt.

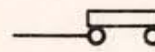

Contact sluit wanneer de spoel bekrachtigd wordt.

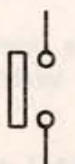

Contact sluit wanneer de spoel bekrachtigd wordt.

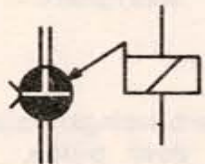
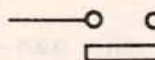

Rechtstreeks werkende elektroklep.

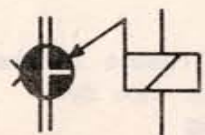

Onrechtstreeks werkende elektroklep.

