

Ⓑ

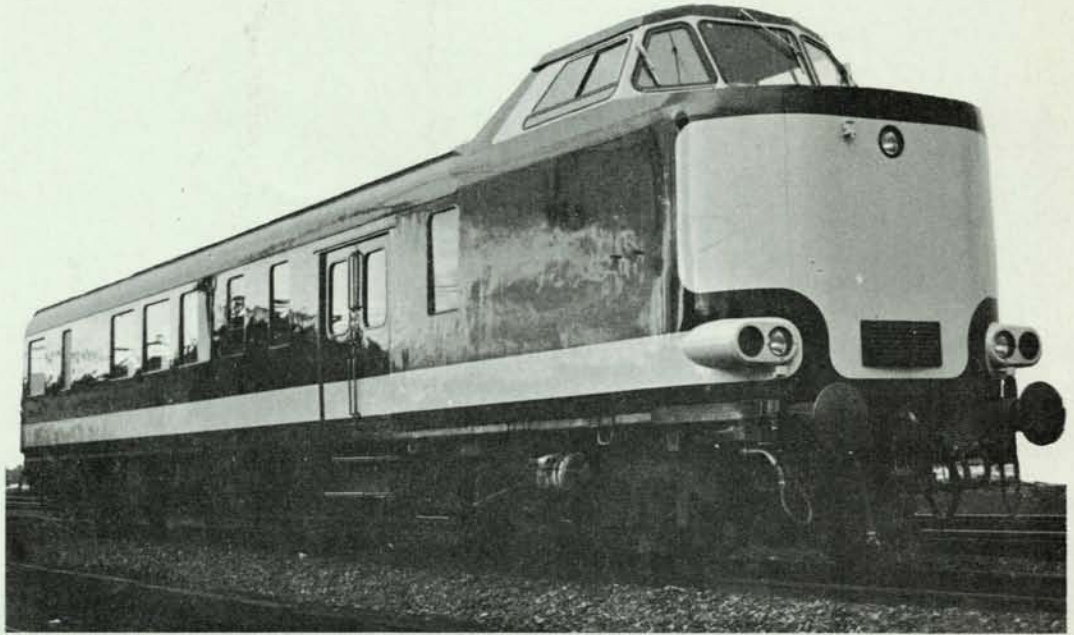

HVR.E

1,5kV 3kV

SCHEMAS

M.A.
24-12

Légende	Appar. Toest.	File Blz.	Verklaring (2)
<u>Electrovalves.</u>			<u>Elektrokleppen.</u>
E.V. inverse veille autom.	EVIHM	5	E.K. aut.Waak.(normaal open)
Sifflet indic. vitesse	EVT	6	Fluit snelheidsmeter
<u>Interrupteur-Cont-Relais.</u>			<u>Schakelaar-Kont-Relais.</u>
Contrôle aut.du train(N.S.)	ATB	-	Autom. treinbeïnvloeding(NS)
Bouton-poussoir purge frein	BPP	6	Drukknop spuien rem
Contact A.T.B.	BRR	6	Kontakt van A.T.B.
Cont. robinet mécanicien	CRM	5/6	Kont. Machinistenkraan
Cont.rob.isol.frein direct	CIFD	5	Kont.afzond.kraan rechtstr. rem
Eclairage porte-horaire	DJ 3	8	Verlichting dienstregeling
Contact ATB	ECSR	5	Kontakt van A.T.B.
Génératrice indic.vitesse	GT	6	Generator snelheidsmeter
Choix de couplage	ICC	9	Spanningskiezer
Inter.phares code/route	JCR	8	Schakelaar dim/groot licht
Indic.fuites frein autom.	IFF	7	Lekmelder aut. rem.
Inter. élimination SWC	I 1	6	Schakelaar afzond. SWC
Inter. élimination V.A.	I 5	5	Schakel.afzond.aut.waak.
Inter.essais lampes signal	I 9	7	Schakel.beproeven meldlamper
Manette d'inversion	M 1	10	Rijrichtingwals
Volant de vitesse	M 2	10	Hoofdschakelwals
Manette d'effort	M 3	10	Trekkrachtregelwals
Pédale veille autom.	PVA	5	Pedaal aut. waak.
Relais auxil.veille autom.	RAHM	5	Hulprelais aut. waak.
Relais temporisé 4" veille autom.	RHM 4"	5	Tijdrelais 4" aut. waak.
Cont,rob.isol. veille autom	RIVA	5	Kont.afzond.kraan aut.waak.
Relais temporisé 60" veille autom.	RR 60"	5	Tijdrelais 60" aut. waak.
Relais Switch control	RSWC	6	Relais control Switch
Résistance réglable GT	RTI	6	Regelweerstand GT
Inter.élimination A.T.B.	SG	6	Schakelaar afzond. A.T.B.
Phare N.S.	SJI	8	Koplicht N.S.
Phares	SJ2	8	Kopluchten
Code/route	SJ3	8	Dim/groot licht
Blanc/rouge	SJ4	8	Wit/rood licht
Phares rouges côté cuisine	SJ5-6	8	Rode lichten kant keuken
Eclairage cabine	SJ7	8	Cabineverlichting
Eclairage appar. mesure	SJ8	8	Meterverlichting
Switch-control(cond.frein)	SWC	6	Control-Switch (remleid)

Légende	Appar. Toest.	File Blz.	Verklaring ④
<u>Divers</u>			<u>Verschillende</u>
Amp. mètre mot. traction 1/3	A 1.3	5	Amp. meter traktiemotoren 1/3
Amp. mètre mot. traction 2/4	A 2.4	5	Amp. meter tractiemotoren 2/4
Coffret impuls.brosse Télloc.	CPT	6	Impulsenkoff.Télocborstel
Enregistreur de vitesse	RT 12	6	Registr. snelheidsmeter
Resistance voltmètre H.T.	RVHS	5	Weerstand H.S. voltmeter
Voltmètre H.T.	VHS	5	H.S. Voltmeter
Voltmètre B.T.	VLS	5	L.S. Voltmeter

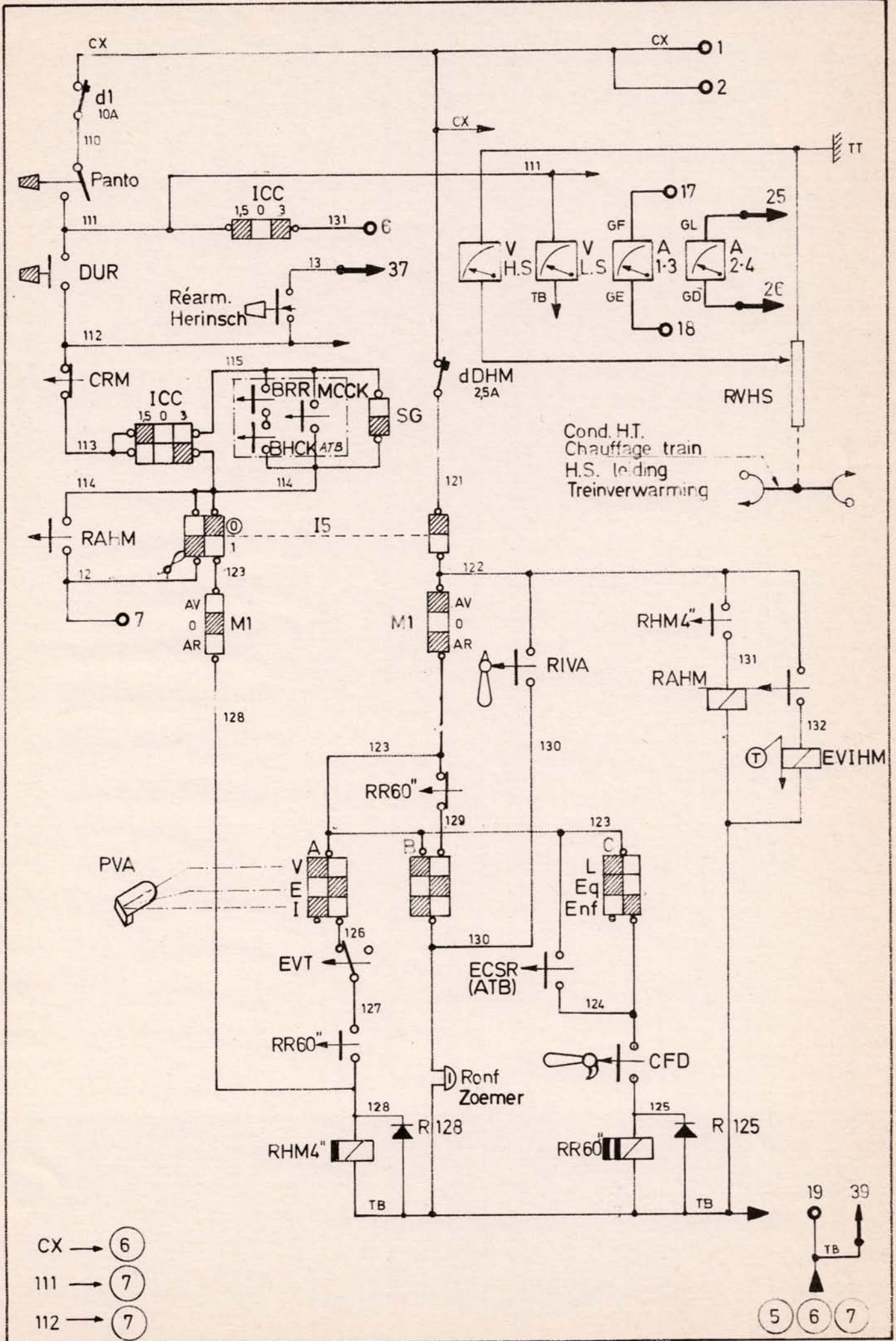

- CX → 6
- 111 → 7
- 112 → 7

- 19 → 5
- 39 → 6
- TB → 7

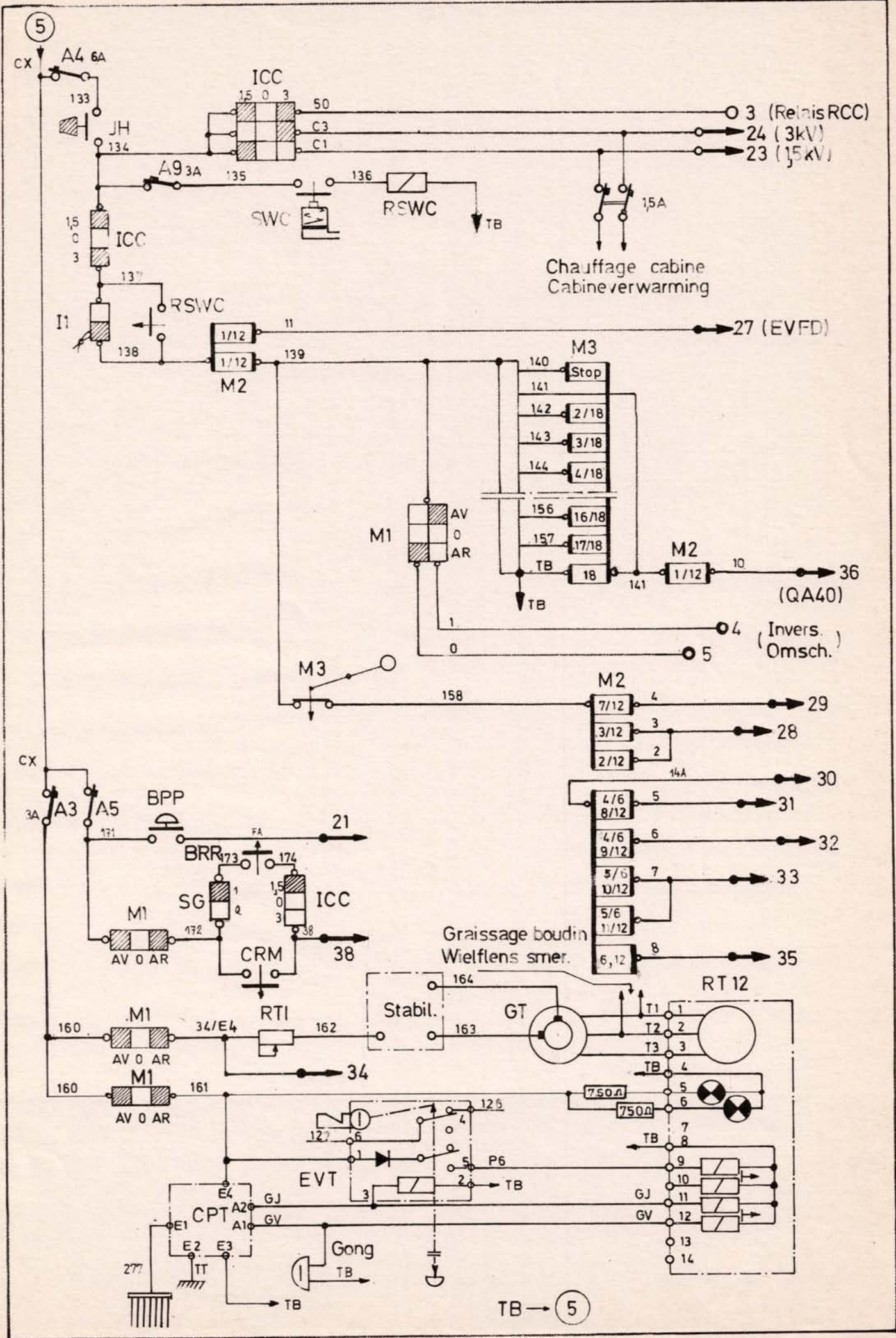

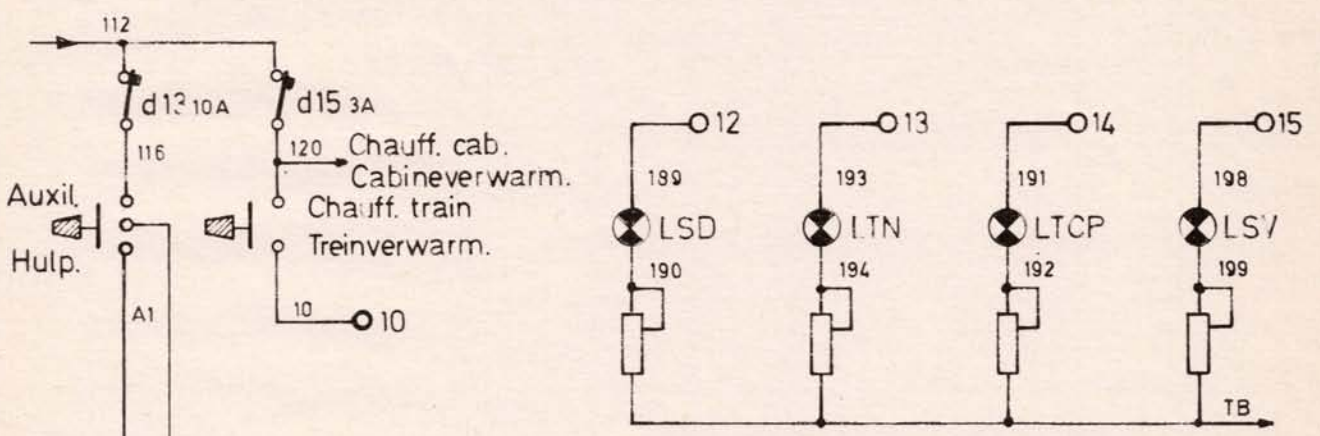
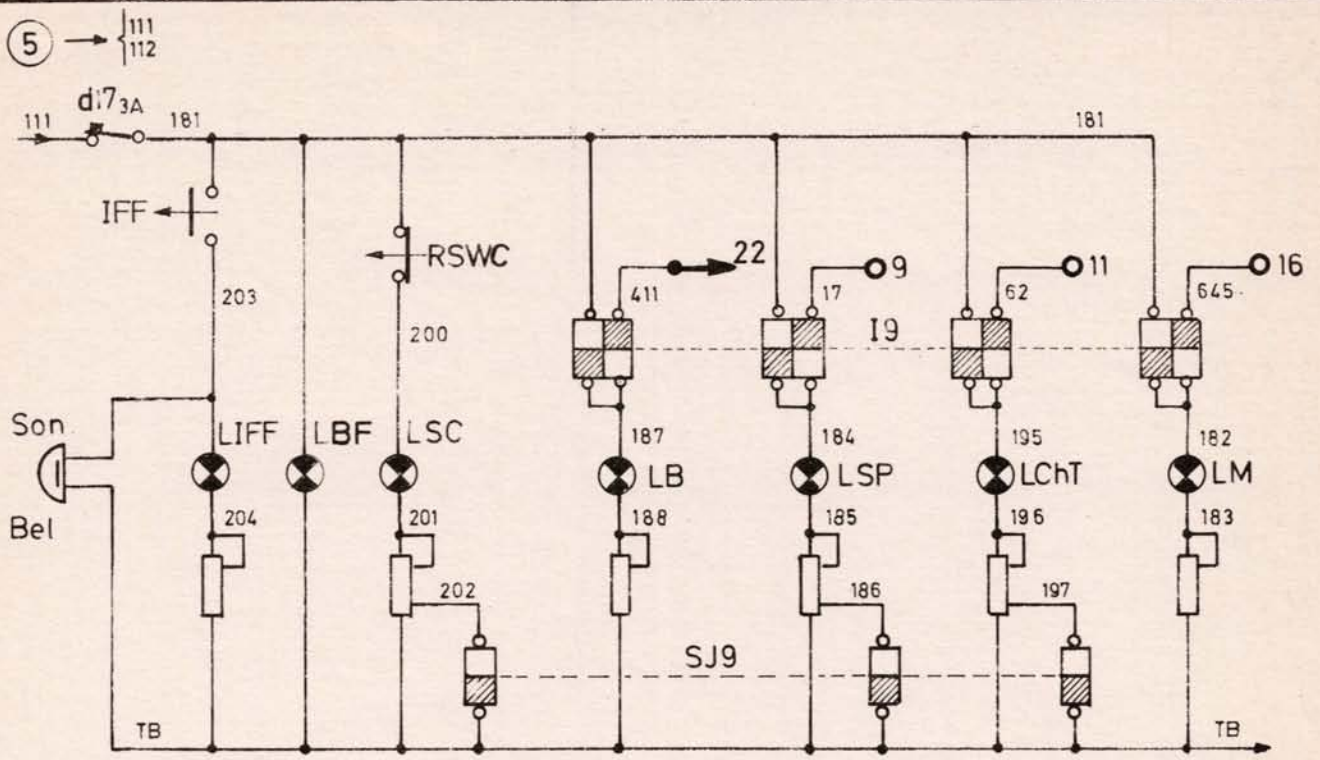

Phares
Kopluchten

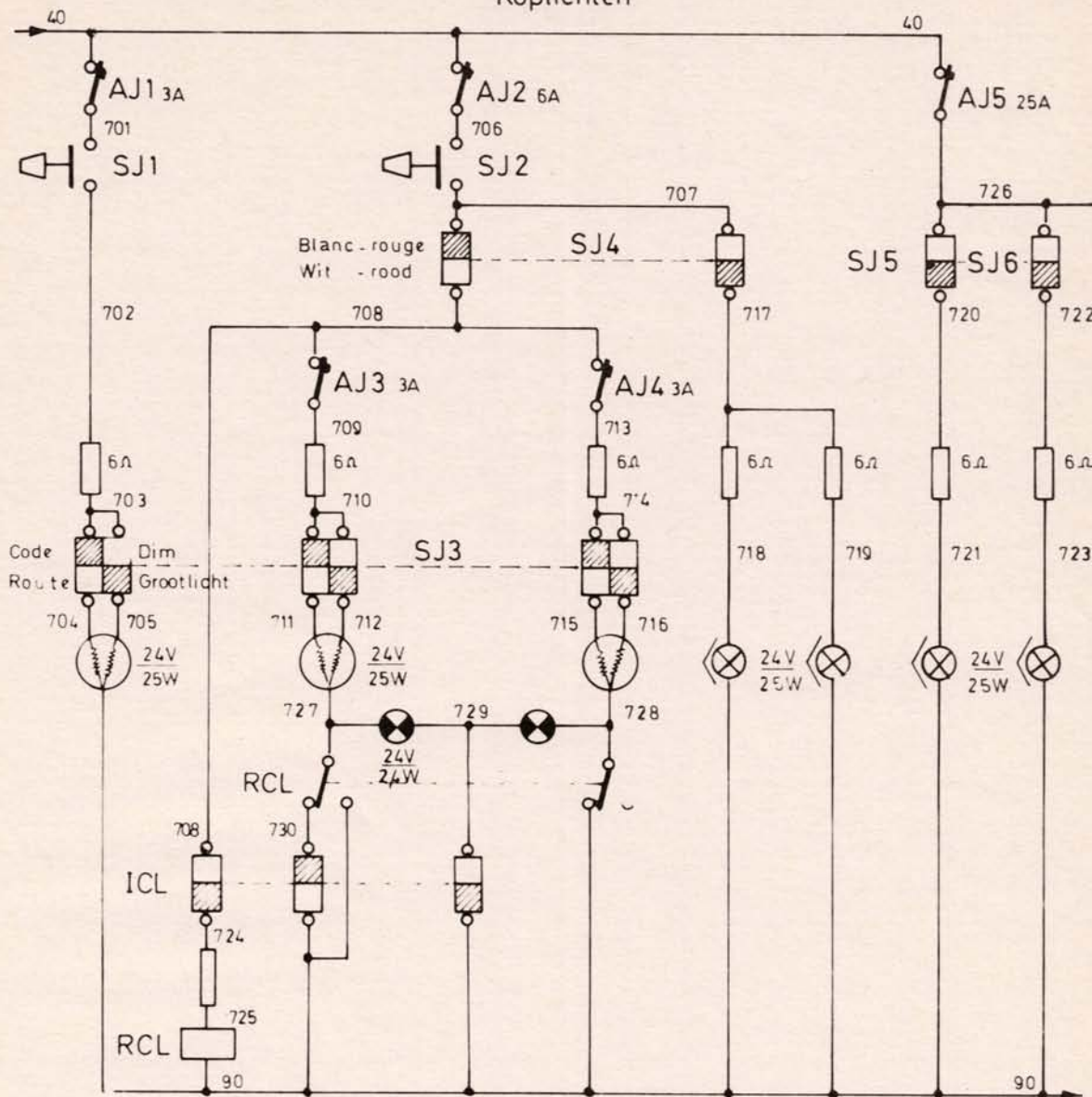

Lanterne de secours
Noodseinlantaarn

Eclair. cab.
Cabineverlicht.

Eclair. porte-horaire
Verlicht. dienstregel.

Eclair. app. mes.
Meterverlichting

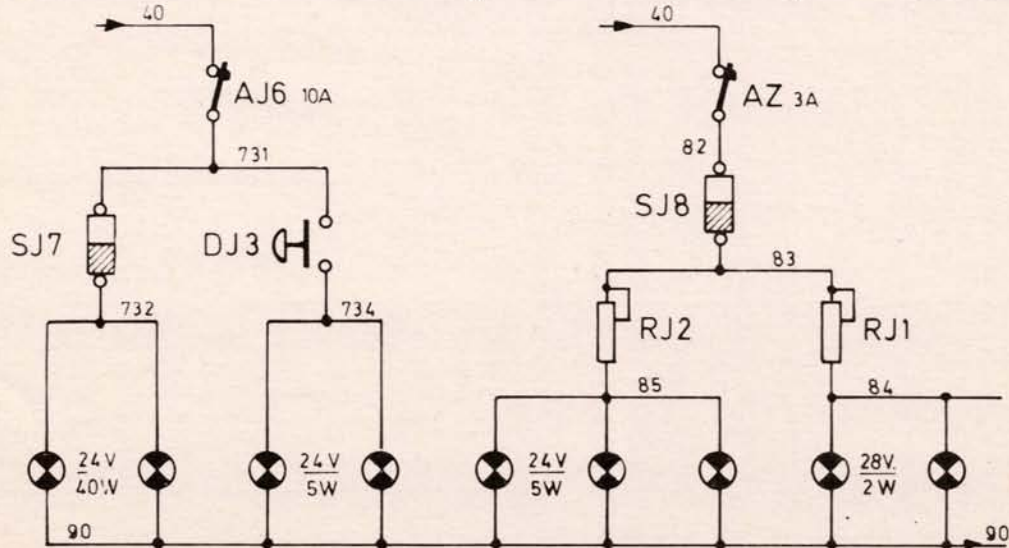
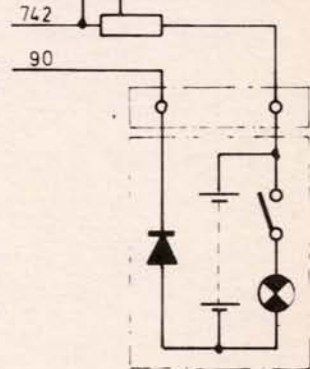

Panto	DUR	Auxil Hulpd.	Anti buée Wasemw.	Chauff. tr Treinverw.	JH
Réarm. Herinsch.	Blanc-rouge Wit-rood	Phares Koplicht.	Eclair. cab Verlicht.kab.	Phare N.S. Koplicht N.S.	Rés

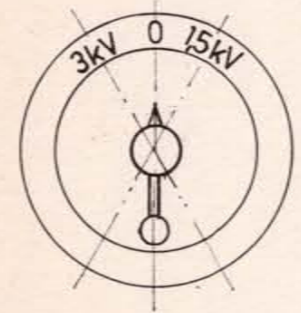
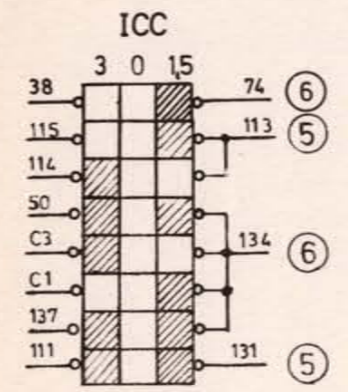
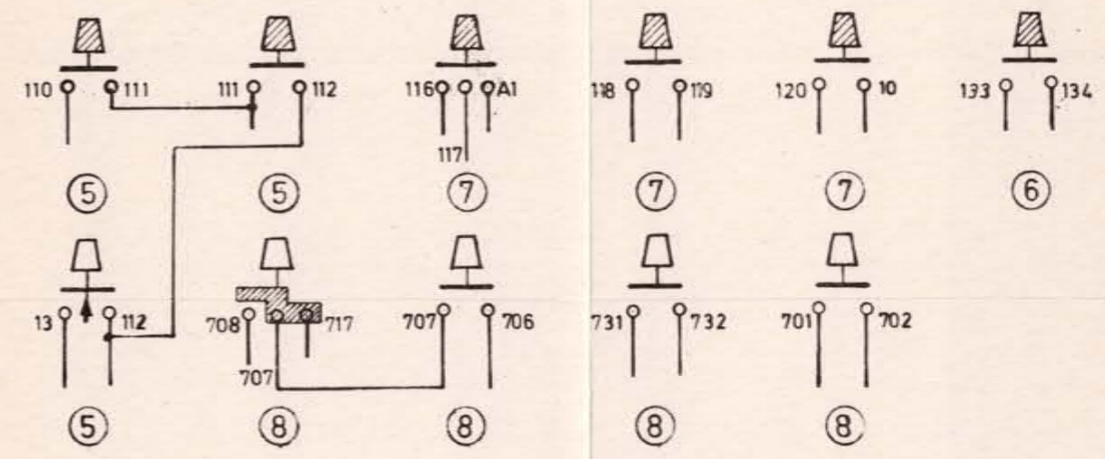

Coupleur - Koppeldoos 1 à tot 19

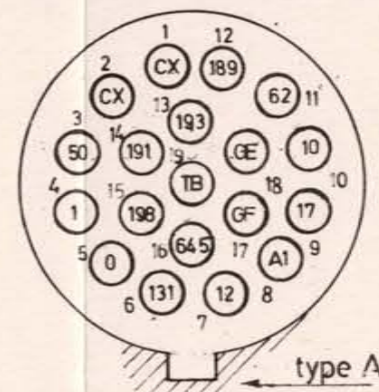

00 + n^r = 1 à tot 19

Coupleur Koppelaar 21 à tot 39

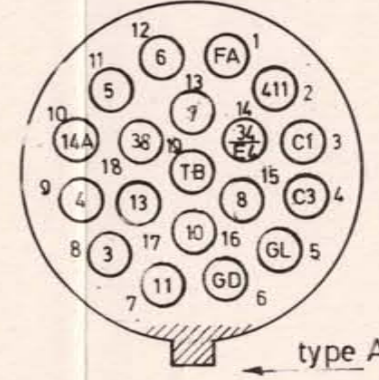

20 + n^r = 21 à tot 39

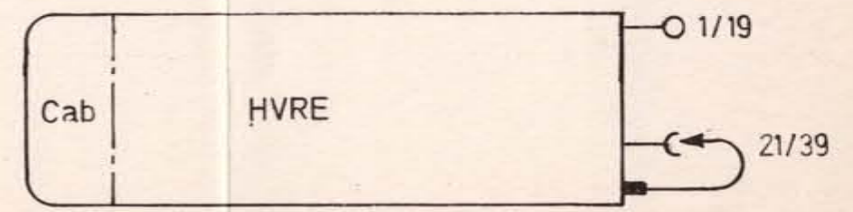

M3 Manette d'effort – Trekkraftregelwals

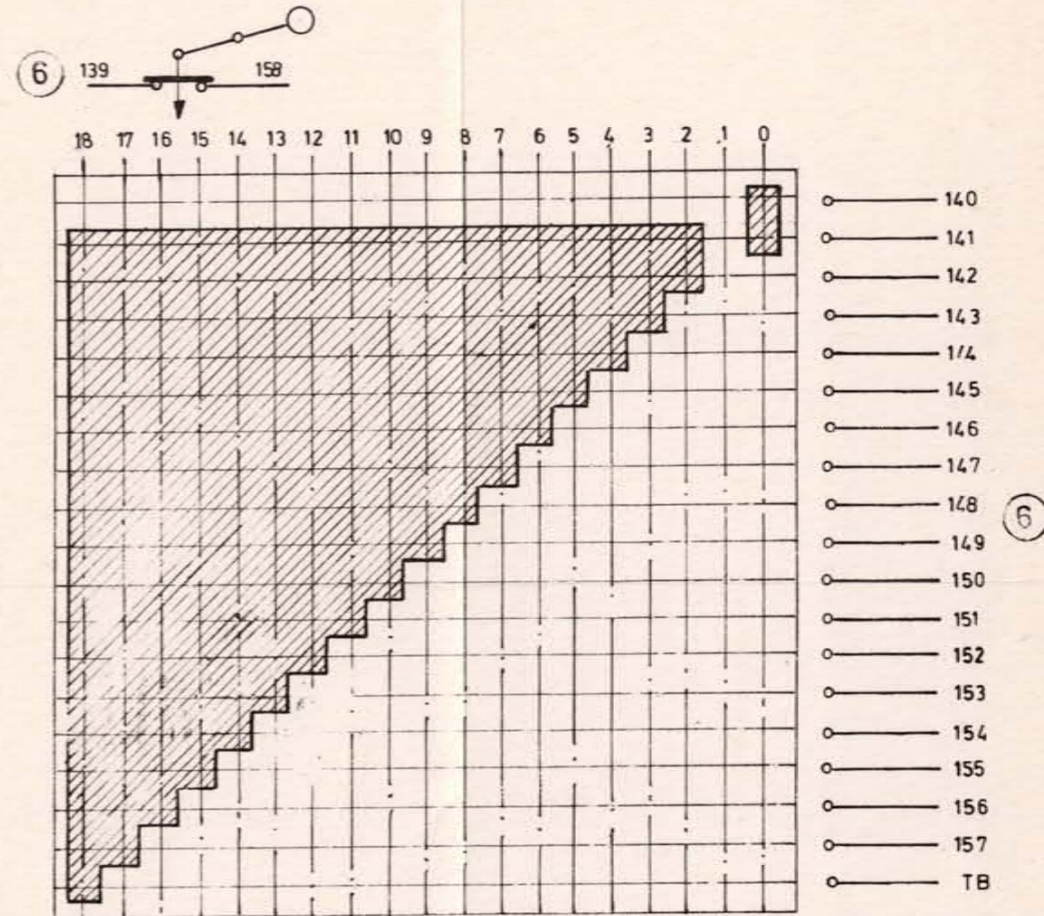

M1 Inverseur Rijrichtingswals

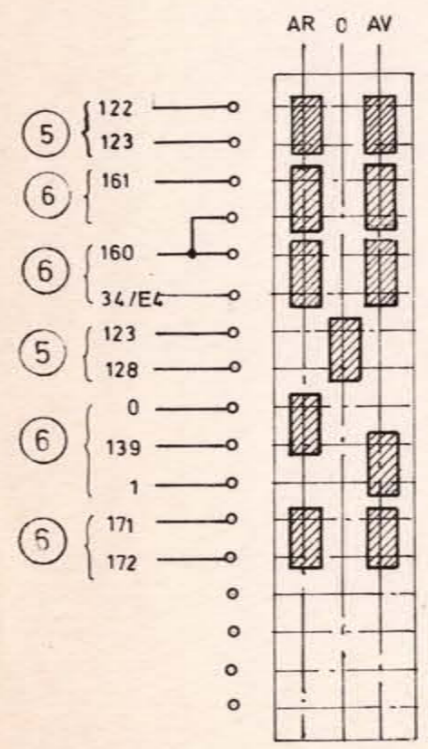

M2 Manette de vitesse Hoofdschakelwals

